

Bar Code Printing Scale & Cash Register Scale

User Manual

2014.3 V2.50A

Preface

Thank you for use the product. Before you start to use this product, please be sure you have read the content in the *Preface* and follow these guidelines.

Notice

- Make sure the electric plugs and wires are all properly connected, and use the 3-cell electric wire only. If an extension-board is used, the outlet of the extension-board is also 3-cell. Make sure the earth wire is properly connected to the earth in order to prevent the leakage of electricity.
- Don't touch the electric plug with wet hand, in case of electric shock.
- Don't lean your body on the scale to avoid damaging the load cell.
- Don't impact the scale or shock the scale with heavy goods, in case of damaging the load cell. When weighing, don't exceed the maximum weighing range
- Don't get the product rained or washed by water; If there is some water on the product by inadvertence, please wipe it clean with a dry cloth; If the scale doesn't work normally, please send the scale to our distributor as soon as possible. We shall do our best to service you.
- Don't put the scale in the places which are ultimately cold, hot or wet. These working conditions may make the product not work normally or damage the product.
- Don't use organic chemistry solutions to wipe the surface and the panel of the product.
- Don't try to take the scale apart and repair the scale by non-professional staff.
- Don't put your hands into the product through the place where the printer spins out. It may cause electric shock with 110V/220V electricity.
- Cut the connection between the scale and AC electricity when taking the scale apart under the guidance of professional staff from our company.
- Don't try to disassembly the switch power inside of the scale. Because it takes a long time to discharge the high voltage capacitance, and it's very dangerous to disassembly the switch power when the high voltage capacitance is not fully discharged.
- **Strongly recommend users to use thermal paper sold by our company. The scale can have a longer life if working with thermal paper sold by our company because we have done a lot of experiments and optimizations on the our thermal paper. On contrary, the life span of the printer may get shortened if the printer works with the thermal paper, which is likely to deposit or leave carbon deposits.**
- **Thermal header is a precise instrument. Don't touch it with fingers or sharp goods. Always use the accessory cleaning tools to keep the header clean.**

Guide to Read

- Please go to page 7 *Thermal Printer* and learn the method to install paper and notices for users.
- Please read page 2 *General Functions, Configuration and Using Index* carefully first in order to know about the performance of the scale.
- Please read page 16 *Fast Prog* carefully first , and learn frequently used programme operations of the scale.
- For ordinary users, please first read page 21, the two chapters *Transfer and Lock of PLU* (page 21) and *Manual Goods Sale* (page 22) in the *Sale Operations*, and learn general sale operations of the scale.
- For ordinary users, read page 63 *Account Operations*, get to know how to print the report forms and delete the records. And read *Operations of Sale Buffers* in page 31 to learn how to look over the recent sale records.
- For advanced users, read the rest of *Sale Operations*, and learn auto mode and other functions.
- For professional users, such as managers in big supermarket, should continue reading the rest of the instruction.
- **When error warning shows up, check *Reference Table For Errors and Its Instructions* in page 70 .**

Abbreviations and Glossary

- PLU: Price of LookUp. It's a cell which contains the information of goods
- Weight PLU, Count PLU: By-weight PLU, By-Count PLU.
- Dept., Class: Dept. is short for department, is the largest category in sales statistics. Class is the second largest category in sales statistics.
- U.Price, T.Price: Unit Price and Total Price.
- Single T.Price, Sum T.Price: Single T. Price means the price of certain goods, while Sum T. Price means the price of total trade.
- Prog, F-Prog: Name of keys, Short for programme and Fast Programme.
- T-Sale: Temporarily Sale. Trade goods is not an exist PLU. Sell them by input a manual price. And the scale will think the goods as PLU 1 (Weight), or 2 (Count).
- Spec: Specification. It is made up of many number parameters, which determines the operation flow and working state.
- TMSet: Working parameters setting.
- DTSet: Working date setting.
- Amount: The quantity of the goods, weight or count. It means weight (kg, lb) for weight PLU and count (pcs) for count PLU
- **【Text】** : Mark the *Text* as a key name.
- **[[Text]]** : Mark the *Text* as a display indication name.

Menu

Preface	i
Notice	i
Guide to Read	ii
Abbreviations and Glossary	ii
Menu	iii
Examples Menu	viii
1 Components of Barcode Print Scale	1
1.1 Check Accessories	1
1.2 Keyboard	1
1.2.1 The Original Overlay of the Keyboard	1
1.2.2 Instructions for Keys.....	2
1.2.3 Instruments for Keys in Function Area.....	2
1.2.4 Character Input Instructions.....	3
1.3 Display Panel.....	5
1.3.1 Sketch Map of Display Panel.....	5
1.3.2 Indication Signs	5
1.3.3 Expression of Characters	6
1.3.4 Dot Matrix Display	7
1.4 Specifications	7
1.5 Thermal Printer (bar code label printing scale only)	7
1.5.1 Install Gap Paper.....	7
1.5.2 Gap Paper Mounts Recycle	9
1.5.3 Install Plain Paper.....	9
1.5.4 Operations Concerning Paper	9
1.5.5 Abnormity of Gap Paper Print	9
1.5.6 Specification for printing interface	10
2 General Functions, Configuration and Using Index	11

2.1	General functions	11
2.2	Setting of Print Format	11
2.3	Barcode printing and scanning	12
2.4	Measure Functions	12
2.5	Sale Functions	13
2.6	Salesman Function	14
2.7	Report Functions	14
2.8	Sales details	14
2.9	Network function.....	14
2.10	Ethernet Thermal Printer	15
2.11	Software use	15
3	Fast Prog.....	16
3.1	Fast-Prog of PLU.....	16
3.2	Fast-Prog of Shortcut Key for PLU.....	18
3.3	Fast-Prog of Spec Parameters	19
3.4	Fast-Prog of Unit price	20
4	Sale Operations.....	21
4.1	Transfer and Lock of PLU.....	21
4.1.1	Transfer by Using PLU Number	21
4.1.2	Transfer by Using PLU Shortcut Keys.....	21
4.1.3	Transfer Temporary Weight PLU.....	22
4.1.4	Transfer Temporary Count PLU	22
4.2	Manual Goods Sale	22
4.2.1	Sale and Print of Single Weight Goods.....	22
4.2.2	Sale and Print of Single Count Goods	23

4.2.3 No Weigh Sale for Weight Goods	23
4.2.4 Sale and Print for Different Kinds of Goods (No Cashing Mode).....	24
4.2.5 Sale and Print for Different Kinds of Goods (Cashing Mode, Input Payment)	24
4.2.6 Sale and Print for Different Kinds of Goods (Cashing Mode, Payment Equal to Price)	25
4.3 Discount Operations	25
4.3.1 U.Price Discount.....	25
4.3.2 T.Price Discount.....	26
4.3.3 ±% price.....	26
4.3.4 Auto Discount	27
4.3.5 Unit Conversion of Temporary U.Price	27
4.4 Setting and Lock of Tare	28
4.4.1 Weight Tare.....	28
4.4.2 Number Tare	28
4.4.3 Lock and Unlock of Tare	28
4.5 Special sale mode	29
4.5.1 Enter and Exit of Special sale Mode.....	29
4.5.2 Sale under batch print mode	29
4.5.3 Sale under prepack mode (only for weight PLU)	30
4.5.4 Sale under Lock PLU mode.....	30
4.5.5 Auto print mode (only for weight PLU)	31
4.6 Operations of Sale Buffers	31
4.6.1 Switch of Sale Buffers	31
4.6.2 Cancel Sale Data in Sale Buffers	31
4.7 Salesman and Waiter	32
4.7.1 Personnel Information	32
4.7.2 Salesman Function.....	32
4.7.3 Waiter Function.....	33
4.8 Inquiry of Sale Records and Markers of Returns of Goods	33
4.9 Manual Weight	34
4.9.1 Manual Sale of Manual Weight Entry.....	34
4.10 Bar code printing and scanning	34
4.10.1 Exterior bar code.....	34

4.10.2 Interior bar code.....	34
5 Programme Operations.....	35
5.1 Please Read this Part First	35
5.2 Basic Operations in Programme Interface	35
5.2.1 Tree-shaped Design of Edit Steps	35
5.2.2 Frequently-used Keys in Prog Interfaces.....	36
5.2.3 List of Programme Interface	37
5.3 The Edit of All Parts in TMSet.....	43
5.3.1 Time Programme	43
5.3.2 Programme of Spec Parameters.....	43
5.3.3 Programme of Text Parameters.....	44
5.3.4 Programme of PLU Shortcut Keys	44
5.3.5 Programme of Fuction Shortcut Keys	45
5.4 The Edit of All Parts in DTSet	45
5.4.1 Department Programme.....	45
5.4.2 Class Programme	46
5.4.3 PLU Programme	46
5.4.4 Unit Programme.....	48
5.4.5 Barcode Programme	49
5.4.6 Print Formats Programme.....	52
5.4.7 Salesman Programme	55
5.5 Assistant Data Programme	56
5.5.1 Steps Select of PLU Programme	56
5.5.2 Steps Select of PLU Fast Programme.....	56
5.5.3 Delete Sale Data	57
5.6 Communication and Data Update	58
5.6.1 Operations of files in USB flash Disk.	58
5.6.2 Ethernet Monitor Interface.....	59
5.6.3 RS232 Communications	60
5.7 Hardware Assistant.....	60
5.7.1 Validate Code.....	60
5.7.2 Password.....	60

5.7.3 Recover Factory Default Setting.....	61
6 Account Operations.....	63
6.1 List of Account Interfaces	63
6.2 Operations of Printing Report	63
6.2.1 Print Total Report.....	63
6.2.2 Print Department Report.....	64
6.2.3 Print Class Report.....	65
6.2.4 Print PLU Report	65
6.3 Clear Report Information	65
6.3.1 Clear Report Information Manually	65
6.3.2 Clear All Reports and Records Information.....	66
6.3.3 Clear stock information.....	66
6.3.4 Reposition SID information.....	67
6.4 Stock Management	67
6.4.1 Stock Management	67
6.4.2 Stock Print	67
6.4.3 Stock Audit	68
6.5 List Print	68
6.5.1 Sale Log	68
6.5.2 List Print.....	68
7 Appendix.....	70
7.1 Reference Table For Errors and Its Instructions.....	70
7.2 Definitions of Spec data parameters.....	73
7.3 Definitions of String data paremeters.....	88
7.4 Definitions of Shortcut Function Key	88

Examples Menu

Example 3-1 Fast-Prog of PLU	16
Example 3-2 Fast-Prog of Shortcut Key for PLU. Amend a shortcut key.	18
Example 3-3 Fast-Prog of Shortcut Key for PLU. Amend two or more shortcut keys.....	18
Example 3-4 Fast-Prog of Spec Parameters	19
Example 3-5 Fast-Prog of unit price (Spec083=1)	20
Example 3-6 Fast-Prog of unit price (Spec083=2)	20
Example 4-1 Use PLU Number to Transfer Weight PLU.....	21
Example 4-2 Use PLU Number to Transfer Count PLU	21
Example 4-3 Use PLU Shortcut Keys to Transfer Weight PLU	21
Example 4-4 Use PLU Shortcut Keys to Transfer Count PLU.....	21
Example 4-5 Transfer Temporary Weight PLU	22
Example 4-6 Transfer Temporary Weight PLU with a Unit Conversion of the U.Price.....	22
Example 4-7 Temporary PLU number is decided by Spec094(default 9999998)	22
Example 4-8 Sale for Single Weight goods	22
Example 4-9 Sale and Print for Single Count goods	23
Example 4-10 No Weigh Sale for Weight PLU	23
Example 4-11 Sale and Print for Different Kinds of Goods (No Cashing Mode)	24
Example 4-12 Sale and Print for Different Kinds of Goods (Cashing Mode, Input Payment).....	24
Example 4-13 Sale and Print for Different Kinds of Goods (Cashing Mode, Payment Equal to Price).....	25
Example 4-14 Execute Discount in Subtraction	25
Example 4-15 Execute Discount at a Fixed Number.....	25
Example 4-16 Input data to execute $\pm\%$ price	26
Example 4-17 Enterinterface and execute $\pm\%$ price.....	26
Example 4-18 Directly execute default $\pm\%$ price(Spec114).....	27
Example 4-19 Auto Discount.....	27
Example 4-20 Unit Conversion of Temporary U.Price.....	27
Example 4-21 Weight Tare	28
Example 4-22 Number Tare.....	28
Example 4-23 Tare Lock and Unlock	28

Example 4-24 Single key select of sale mode	29
Example 4-25 Interface select sale mode	29
Example 4-26 Batch Print mode.....	29
Example 4-27 Prepack mode(only for weight PLU)	30
Example 4-28 Switch of Sale Buffers.....	31
Example 4-29 Clear All Data in Current Sale Buffers.....	31
Example 4-30 Clear One Goods in Current Sale Buffer.....	32
Example 4-31 Inquiry of Sale Records and Markers of Returns of Goods	33
Example 4-32 Manual Sale of Manual Weight Entry	34
Example 5-1 Time Programme.....	43
Example 5-2 Programme of Spec parameters.....	43
Example 5-3 Programme of Text Parameters	44
Example 5-4 Programme of PLU Shortcut Keys.....	44
Example 5-5 Programme of Fuction Shortcut Keys.....	45
Example 5-6 Department Programme	45
Example 5-7 Class Programme	46
Example 5-8 PLU Programme.....	47
Example 5-9 Unit Programme	49
Example 5-10 Barcode Programme.....	49
Example 5-11 Salesman Programme	55
Example 5-12 Steps Select of PLU Programme	56
Example 5-13 Steps Select of PLU Fast Programme	56
Example 5-14 Delete PLU20~30.....	57
Example 5-13 Load Files in USB Flash Disk.....	58
Example 5-14 Save working data to Files in USB Flash Disk	58
Example 5-15 Save sale list to Files in USB Flash Disk	59
Example 5-16 Enter Ethernet Monitor Interface	59
Example 5-17 Process of Amending Passwords.....	61
Example 5-18 Process of Amending Passwords.....	61
Example 6-1 Print Daily Reports of Today and Yesterday	64
Example 6-2 Print PLU Daily Reports with the Numbers from 10 to 20.....	65

Example 6-3 Clear Information in Manual Report..... 66

Example 6-4 Clear All Reports and Records Information 66

Example 6-5 Clear stock information..... 66

Example 6-6 Clear manual report..... 67

Example 6-7 Print stock Reports with the Numbers from 10 to 20..... 67

Example 6-8 Amend PLU10 stock to 100 68

Example 6-9 Intraday List Print 68

Example 6-10 Appointed Time Period List Print..... 69

1 Components of Barcode Print Scale

1.1 Check Accessories

- One Scale;
- One tray;
- One display pole (pole type only);
- One pack of screws used to fix the pole (pole type only);
- One copy *User Manual* (this book);
- One CD for PC software *TM-xA Management Software*
- One overlay for shortcut PLU;
- One power plug;

1.2 Keyboard

1.2.1 The Original Overlay of the Keyboard

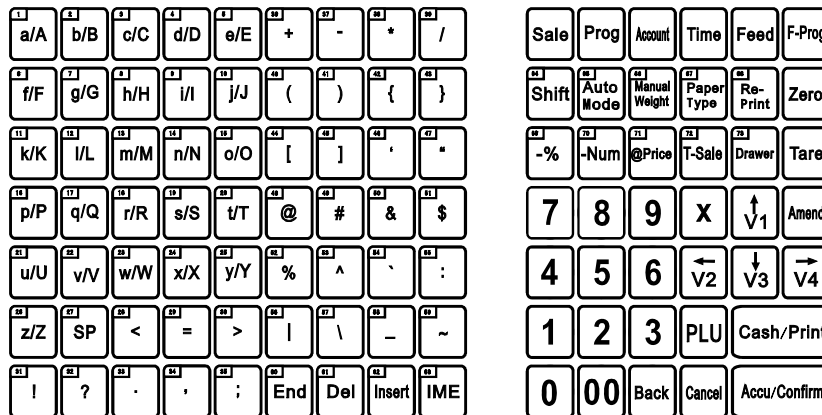

Picture 1-1 Sketch Map of Keyboard Function for barcode label printing scale (Pole)

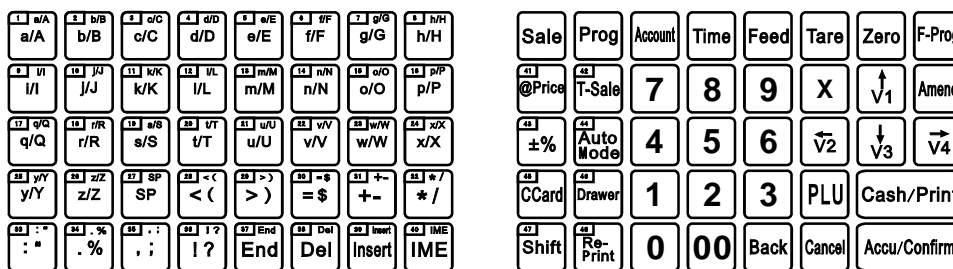

Picture 1-2 Sketch Map of Keyboard Function for barcode label printing scale (Bench)

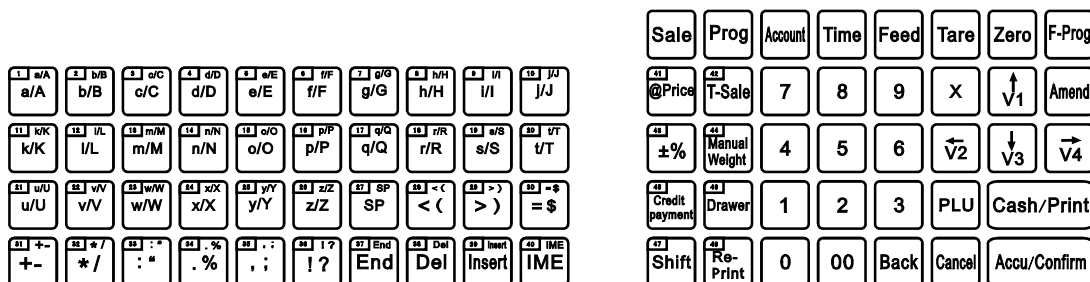

Picture 1-3 Sketch Map of Keyboard Function for cash register scale

The graph above shows the original definitions. Some buttons on the left top area are marked with numbers, which are serial number for the shortcut keys. In this text, **【SCxx】** is used to represent shortcut keys. For example, **【SC1】** represents the first key on the left top marked with number 1. **【SCxx】** on the left side are PLU preset shortcut keys and can be set to represent one certain key if user requests. When editing the text, **【SCxx】** are function keys and character keys for the input of letters. Please refer to chapter 1.2.4. **【SCxx】** on the right side are preset shortcut keys for additional functions. The presetting is shown in the graph. And it's not available for user to change the setting of function keys now.

1.2.2 Instructions for Keys

When you press right keys, the scale would beep shortly to show the operation is right.

When you press wrong keys, the scale will beep in 1 long sound and 2 short sounds. The composite beeps mean the failure in operation process or errors in pressing keys. If operation process fails, there will be Ex.xx displayed on the screen (e.g., E1.01 means programme data is invalid.).

It may take 4 seconds to press one key in the operation which needs to **Long Press** the key without releasing it. During the period you will hear 2 beeps. The first beep sounds as soon as you press the key while the other one sounds 4 seconds after pressing the key.

In some **【F-Prog】+【Other key】** operations, users should first press **【F-Prog】** without releasing and press the **【Other key】** in order to complete the operation.

In the following instruction: **【Key1】【Key2】** means the operation that press **【Key 1】** first and release it, then press **【Key 2】** and release it. **【Key1】 + 【Key2】** means the operation that press **【Key1】** and **【Key2】** at the same time. When users do it, press **【Key1】** first, and press **【Key2】** without releasing **【Key1】**.

1.2.3 Instruments for Keys in Function Area

Picture 1-1 shows the default setting of keys in the function area. According to customer's requests, default setting may be different. And the specific setting will be on the overlay:

- **【Sale】** : Enter sale mode and execute the operation of goods sale.
- **【Prog】** : Enter programme mode and programme on parameters, PLU, print formats, time and so on.
- **【Account】** : Enter Account mode to inquire about deals data or print reports and so on.
- **【Time】** : Display current time and return to the previous interface when you press it again.
- **【Tare】** : Set current weight as tare or appoint certain data as tare (When there is a number in input window, number tare is the priority.). Pressing **【Tare】** for a long time without releasing, system would enter **【Tare Lock】**. And do it again to exit this state.
- **【Zero】** : Clear current weight and reset zero within allowed range. If not within allowed range, set zero would fail.
- **【Shift】** : Shift key used for extending PLU shortcut key, and switching case sensitivity in text input interface. When current input number is decimal (tare, weight, U.Price, T.Price), long press **【Shift】** or press **【F-Prog】 + 【Shift】** would change the position of decimal point.
- **【Auto Mode】 【Pre-Pack Mode】 , 【Batch-Pint mode】 , 【Auto print】【Lock PLU】**: Switch ordinary mode with pther sale mode. Users can long-press this key to enter sale mode select if current sale buffer is empty.

- **【Manual Weight】** :Key for manual entry of weight. “ManWT” will add before weight data while printing. Open this functions in Spec if user needs it.
- **【Paper Type】** : Long Press it switch paper between gap thermal paper and plain thermal paper.
- **【Re-print】** : Repeat last print in current buffer (Repeated print data would not be stored in deal records as sale record.). This function can be forbidden in Spec.
- **【Feed】** : Roll the gap thermal paper and plain thermal paper. Unprinted buffer data will be cleared in the process of feed.
- **【-%】 【±%】** : Discount in percentage, $P_{Dis} = P(1 \pm \frac{Input}{100})$. Please notice that input is decimal and pay extra attention to the position of decimal point. Discount is 5% off while input is 500, if there are two zeroes after decimal point. And input should be 5000, If there are three zeroes. You can refer to Spec113, Spec114 for detailed explanation.
- **【-Num】** : Discount in subtraction. $P_{Dis} = P - Input$. Input is also decimal.
- **【-@】【@Price】** :: Discount to a fixed price. $P_{Dis} = Input$. Input is also decimal. You can also use this key to save the discounted price to PLU directly, please refer to Spec083
- **【T-Sale】** : Set input number as Unit Price and set a temporary PLU. You can amend the temporary weight PLU’s unit in Spec, for example, if the temporary weight PLU’s unit is 500g, but the scaleunit is kg, then system will automatically conversion (multiply 2)
- **【Drawer】** : Open drawer besides normal operations.
- **【Paid by card】** : Obligate function
- **【F-Prog】** : Change some setting or values of PLU fastly in sale mode. It is always used for combination of keys, which is similar as ‘Alt’ ‘Ctrl’ in PC keyboard. Please refer to process instructions to understand the use of combination keys.
- **【×】** : Input count amount in count sale. Or do temporary count goods sale according to input U.Price.
- **【Amend】** : Amend deal data in sale interface and store amended data in programme interface.
- **【←】【↑】【↓】【→】** : Switch among neighbouring steps and numbers in programme and account interfaces.
- **【V1】 ~ 【V4】** : Activate corresponding sale buffers.
- **【0】 ~ 【9】 , 【00】** : Input corresponding numbers.
- **【Back】** : Delete the last digit input number.
- **【PLU】** : Transfer PLU datas using input numbers as serial numbers.
- **【Cash/Print】** : Check out in cash; calculate changes and print labels or receipts according to setting.
- **【Cancel】** : Clear data, cancel operations or go back to previous step.
- **【Accu/Confirm】** : Save accumulative deal data into activated sale buffer and other confirmation operations.

1.2.4 Character Input Instructions

The key of function section remains the same when system enters letters input interface, while **【SC1】** ~

【SC63】 are used to input letters. In input process, definitions of keyboard are shown below:

- 【Amend】 : Confirm text input. Save and exit.
- 【Cancel】 : Cancel edited data and quit without saving.
- 【Confirm】 : Confirm the input in special IME (not used in pure English version).
- 【End】 : Input end character, and all characters after appointed position are deleted.
- 【Delete】 : Delete the character at the position where cursor is.
- 【Insert】 : Switch cover mode with insert mode. Cover mode is activated when cursor is constant on while insert mode is activated when cursor is glittering.
- 【IME】 : Input method editor. Switch the input languages: En-1 (in small letters), En-2 (in big letters), Chs (chinese code), Code (machine code).
- 【Shift】 : Switch En-1, En-2 in temporary state.
- 【←】 【→】 : Move current editing position backwards or forwards.
- 【0】 ~ 【9】 and 【SC1】 ~ 【SC59】 : Input characters or codes.

In the process of input text, meanings of four windows are shown below:

- The first window: Display current input mode: one of En-1, En-2, Chs and Code.
- The second window: Display the position of current editing letters in the text.
- The third window: Display current editing position and content of neighing letters. In En-1 or En-2 ASCII mode is displayed while in Chs or Code Hex mode is displayed. Cover mode is activated when cursor which shows the position is constant on, while insert mode is activated when cursor is glitter.
- The fourth window: Display current input content. In En-1 or En-2 the window displays nothing, and in Code input machine code is displayed.

Switch 4 kinds of input languages by pressing switch keys. Input mode of each kind of input language is shown below:

- En-1 **small letter**: Input numbers or ASCII characters. For the keys with ‘/’, input character is the one on the left of ‘/’. Pressing 【Shift】 , next input character and only this one is under the rule of En-2 .
- En-2 **capital letter**: Input numbers or ASCII characters. For the keys with ‘/’ , input character is the one on the right of ‘/’ . Pressing【Shift】, next input character and only this one is under the rule of En-1 .
- UTF8 (U version IME, for UTF8 font scale use only): UTF-8 input method, input Unicode to get the characters, input different kinds of non-English language characters, please check code from UTF8 Test Editor Manual, after input Unicode, press 【Confirm】 to finish the input
- PY **Chinese pinyin mode** (E version IME, font scale use only): **Input pinyin, and select chinese character by 【←】 【→】** , Press 【Confirm】 to input a Chinese character. In pinyin mode, Press 【Space】 to select SBC case symbol, Press 【Space】 twice to select English symbol.
- Chs **Chinese ISN mode** (E version IME, font scale use only): Input ISN code to select a Chinese character or SBC case symbol.
- Code: Input machine code mode. Users can input ASCII, symbols in special IMEs. The system could

automatically distinguish the input content as ASCII, symbols in special IMEs. Machine codes of each field can be found in following table.

Table 1-1 ASCII Code Table

	0	1	2	3	4	5	6	7	8	9	A	B	C	D	E	F
0	Non-print character															
1	Non-print character															
2		!	“	#	\$	%	&	‘	()	*	+	,	-	.	/
3	0	1	2	3	4	5	6	7	8	9	:	;	<	=	>	?
4	@	A	B	C	D	E	F	G	H	I	J	K	L	M	N	O
5	P	Q	R	S	T	U	V	W	X	Y	Z	[\]	^	_
6	`	a	b	c	d	e	f	g	h	i	j	k	l	m	n	o
7	p	q	r	s	t	u	v	w	x	y	z	{		}	~	
8	Not used															
9	Not used															

1.3 Display Panel

1.3.1 Sketch Map of Display Panel

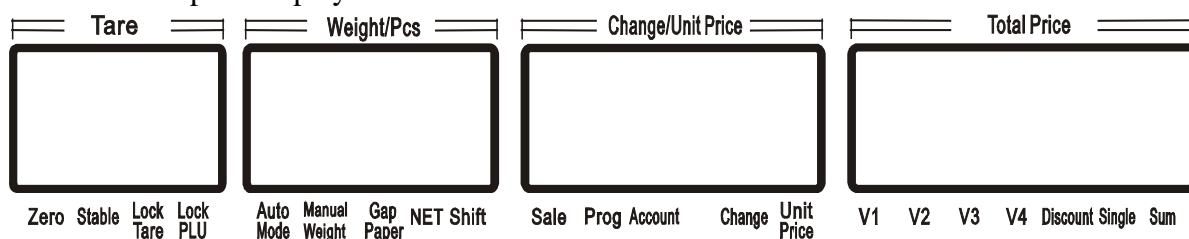

Picture 1-4 Display Overlay

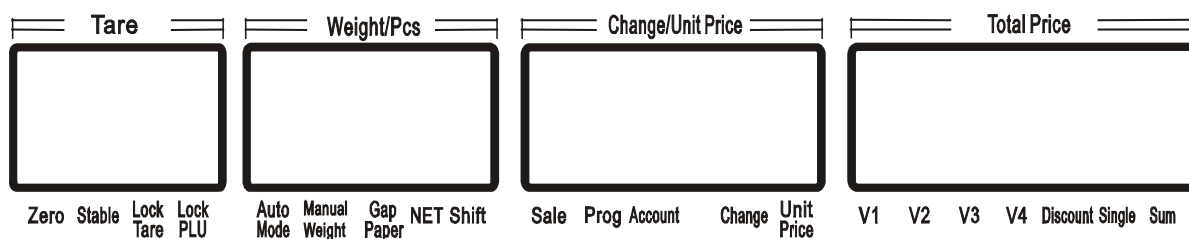

Picture 1-5 Display Overlay with Dot-matrix Display

1.3.2 Indication Signs

- 《Zero》 : It's on when weight is zero and stable.
- 《Stable》 : It's on when weight is stable.
- 《Lock Tare》: It's on when tare is locked. Long press **【Tare】** would lock tare. Under this condition, tare would not be cleared after the sale. Long press **【Tare】** again would exit lock tare.
- 《Lock PLU》 : It's on when PLU is locked. Long press **【PLU】** would lock PLU. Under this condition,

former PLU sale state would remain the same after the sale. And it will last until new PLU is transferred.
 Long press **【PLU】** again would exit lock PLU.

- **〔Auto mode〕**: It's on in auto mode. When in auto mode, lock PLU will active. In this mode, pre-pack or batch print is executed based on Spec078 and Spec079.
- **〔Pre-pack〕** same as **〔Auto mode〕**
- **〔Auto Print〕** the light will on when in auto printing
- **〔Manual Weight〕** :It's on when manual weight is displayed.
- **〔Gap paper〕** : It's on when paper type is gap paper. If it's off when paper type is plain paper.
- **〔NET〕** : It's on when tare is set and net weight is displayed. Press **〔Fast Prog〕〔Tare〕** will display gross weight
- **〔Shift〕** : Press **【Shift】** and it is on.
- **〔Sale〕** : It's on in sale mode.
- **〔Prog〕** : It's on in programme mode.
- **〔Account〕** : It's on in account mode.
- **〔Change〕** : It's on when the data in third window is displayed as cash change.
- **〔U.Price〕** : It's on when the data in third window is displayed as goods U.Price.
- **〔V1〕 ~ 〔V4〕** : It's on when there are buffers in V1~V4 records. And it's glittering in edit mode.
- **〔Discount〕** : To display single means that current goods has been discounted in U.Price; To display total means that current accumulative total has been discounted in T.Price
- **〔Single〕** : It's on when total price of current goods is displayed in fourth window.
- **〔Sum〕** : It's on when the sum total price of current sale buffers (V1~V4) is displayed in fourth window.

1.3.3 Expression of Characters



Picture 1-6 Number Characters 0 ~ 9



Picture 1-7 Characters A ~ M



Picture 1-8 Characters N ~ Z

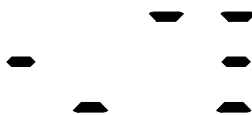

Picture 1-9 Dash、underline, aboveline, three lineations of special symbols

- Dash of special symbols: the same as ‘-’ in ASCII.
- Underline of special symbols: Used to represent the characters which cannot be displayed in ASCII(the symbols except 0~9, A~Z and ‘-’)
- Aboveline of special symbols: Used to represent extended characters. In Chinese edition, two aboveline represent a Chinese character.
- Three lineations of special symbols: In calibrating processes, it’s used as a prompt to decide to enter calibrating interface or standard interface.

1.3.4 Dot Matrix Display

5-windows scales have an additional 160×32 dot matrix LCD display. It displays time or ad-message or accumulation record in idle mode; and displays PLU’s name in PLU mode.

1.4 Specifications

- Power supply: AC200V~240V, 47~53Hz
- Operation temperature: 0℃~40℃
- Conservation temperature: -20℃~70℃
- Operation humidity: 15%~85%RH

Capacity	Resolution	Division	Accuracy
6kg	3000	2g	Ⓜ
15kg	3000	5g	Ⓜ
30kg	3000	10g	Ⓜ

1.5 Thermal Printer (bar code label printing scale only)

1.5.1 Install Gap Paper

Install process is as below: Left is drawer structure (08’s). Right is cover structure (12’s)

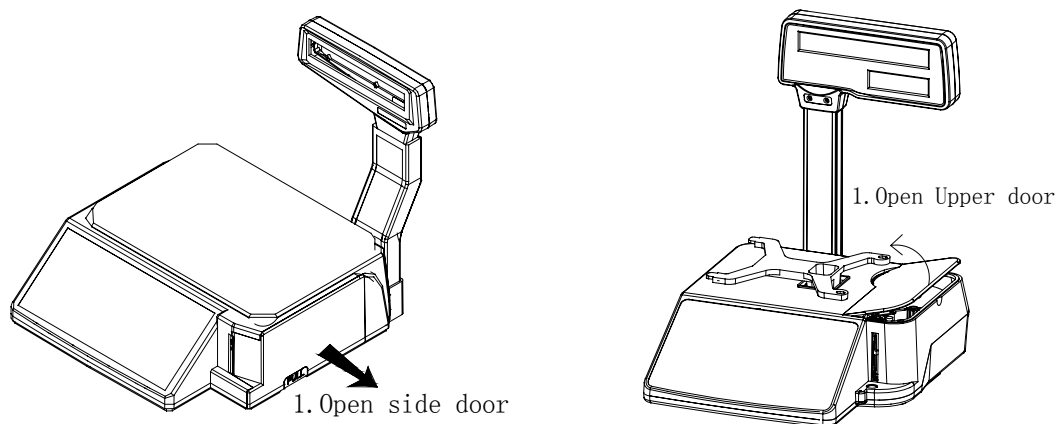

Picture 1-10 Open door of scale printer

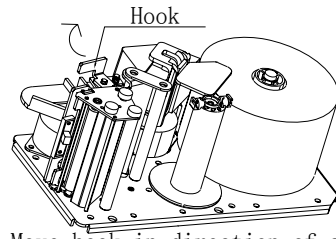
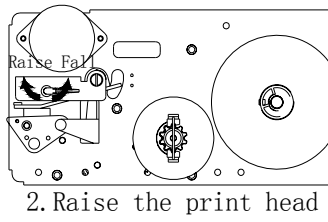

Picture 1-11 Open press mouth

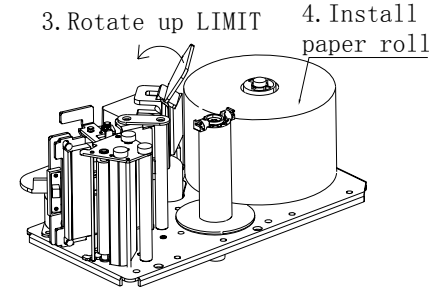
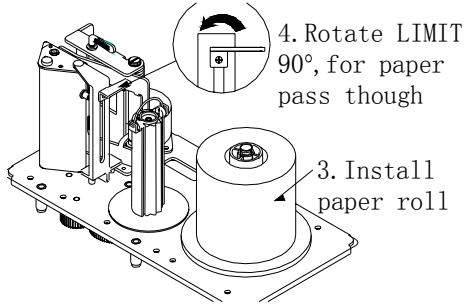

Picture 1-12 Install paper roll

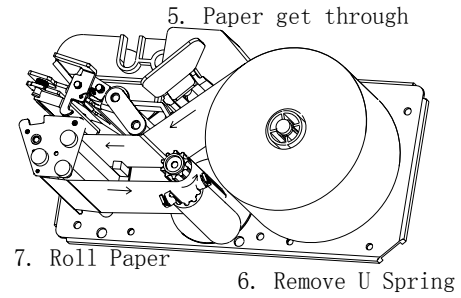
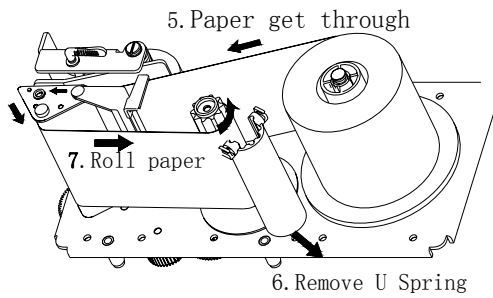

Picture 1-13 Paper through

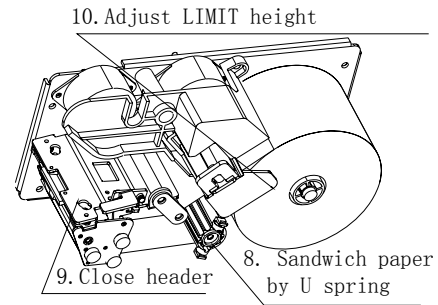
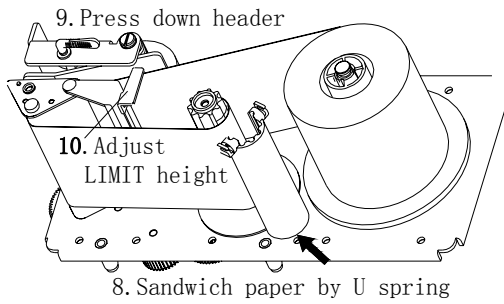

Picture 1-14 Finish paper install

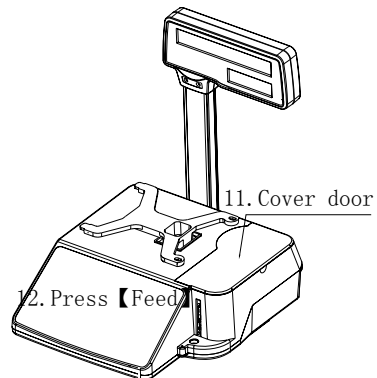
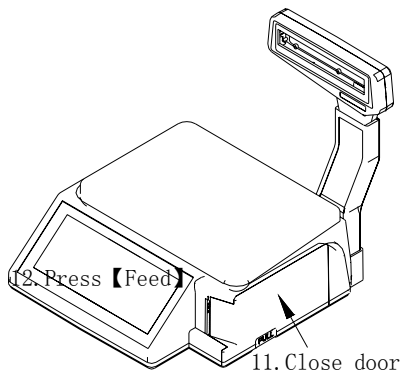

Picture 1-15 Close door of scale printer

1.5.2 Gap Paper Mounts Recycle

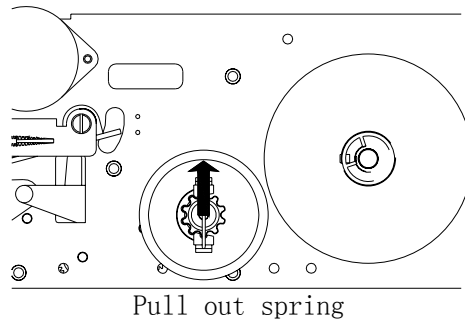

Picture 1-16 Gap paper mounts recycle

1.5.3 Install Plain Paper

Different from the way in installing gap paper shown in 1.5.1, U-shaped paper retaining spring is not needed anymore. All you need to do is to put the paper into the paper sensor and let the tear part be outside.

1.5.4 Operations Concerning Paper

- **【Paper Type】**: Make sure the type of paper set is the same as the type used. When **[[Gap Paper]]** is light in the display, you should set to use gap paper. Otherwise you should set to use plain paper. If the type of paper you set to use is different from the type currently used, please long press **【Paper Type】** to change the set.
- **【Feed】**: After installing the paper, press **【Feed】**. You can also press **【Feed】** to clear abnormalities of the printer and make paper roll for a certain length.

1.5.5 Abnormity of Gap Paper Print

Users of plain paper don't do any adjustment for this.

Abnormity of printer parameters may happen when gap paper prints are unnormal, paper goes out continuously, or printer can't work after one paper is printed, printing parameter maybe have abnormity

Users need to check if paper type is right first. Then users could follow these operations below to eliminate malfunctions:

- Install gap paper, and make the edge of gap paper not exceed print head. (Not block the paper-out sensor)

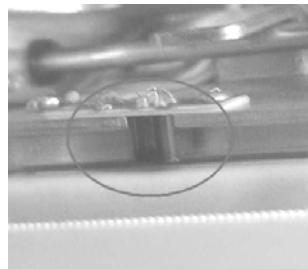

Picture 1-17 Paper-Out sensor

- Switch off the scale. Press the **【Feed】** key then switch on the scale, hold this key until finished self checking and go into work interface
- Printer would roll out the paper at the length of 50mm. automatically
- After the paper is rolled out, malfunctions have been eliminated if without any warning. If alarm E7.10 means calibration abnormity, pls try again after confirming the sticker paper has been used.

- Then, press **【Feed】** to print the test page
- Go to normal operation processes.

1.5.6 Specification for printing interface

Window	Tare	Weight/Count	CHG/Unit Price	U.Weight/T.Weight
Sample	E7.1x		P1-02	Print
Specification	If normal printing, this window is blank, if have error, will display erro message, the mean for message pls refer to Addenda 7.1	When mass printing, this window will display the number rest unprinted.	Display present printing doc and number. P1-01 means the 2 nd page of Doc 1. If total print 1 page, this window will blank.	When printing display: Print Not Printing will display blank.

2 General Functions, Configuration and Using Index

2.1 General functions

- The printer can store 5990 PLUs. (Can extend to 10000 PLUs)
- Users can use gap thermal paper (TM-xA Series) and plain thermal paper.
- The printer provides many kinds of price input and discount.
- The print provides reports print for different time periods and classifications
- Precision of measurement: business mode 1/6000 (1/7500 for 15kg), industrial mode 1/30000.
- Support network, use RS232 and U disc as tool of data transfer, all data can set on the PC, then use these interface to upload and download.
- Save sales details, can upload to PC through above interface
- **5-windows scales have an additional 160×32 dot matrix LCD display.**

2.2 Setting of Print Format

- **Bar Code Printing Scale:** Press **【Paper Type】** for 4 seconds to switch between gap paper and plain paper. This key would amend Spec021.
- **Bar Code Printing Scale:** There are 9 kinds of default print formats. Please reference to *Factory Default Print Formats* in page 52.table 5-5
- **Bar Code Printing Scale:** 58mm*40mm and 40mm*30mm gap paper, 58mm and 40mm width plain paper are available in default print formats. When using different type of paper, please adjust the corresponding Spec shown in the table below.

Paper type	Print type	Spec			Instructions
		000	005	027	
58mm*40mm gap paper	Label print	1	4	50	Default
	Receipt print	7	7	50	Not recommend
40mm*30mm gap paper	Label print	2	5	36	
	Receipt print	8	8	36	Not recommend
58mm width plain paper	Label print	1	4	50	
	Receipt print	7	7	50	
40mm width plain paper	Label print	2	5	36	
	Receipt print	8	8	36	

- **Cash Register Scale:** Cash register scale preset support 55mm width plain paper, default using receipt printing format
- Print formats include label print and receipt print. If user needs custom print format, please use PC software to change or contact with appointed after-service center.
- Don't print bills while saling: amend Spec003 and Spec008 to 0. If some specific deals need to print bills, please press **【Reprint】** .
- To print a few copies of one bill, put the amount into Spec003 and Spec008.

- To print two different kinds of bills: set the type of bill 1 in Spec000~Spec009, and bill 2 in Spec010~Spec019. Strongly suggest users contact with appointed after-service center
- Set grey level of gap thermal paper in Spec022.
- Set grey level of plain thermal paper in Spec023.
- Set plain thermal paper in Spec 025, the position for cut-off paper suggest Spec025 not less than 30
- You can set different kinds of print formats and barcode types for each PLU. You can check the details in PLU parameters for print formats and barcode types. Set the value of these parameters to 0 if you choose the system type.
- The procedures to confirm print format: take bill 1 as an example. If two or more goods are sold, print sum bill and use Spec005 as print format. If only one good is sold, print the item bill. If sale PLU has been set for a specific print format (not 0), system would use the print format. If no specific print format has been set to sale PLU (The setting number is 0.), the print format would be Spec000.

2.3 Barcode printing and scanning

- Can print various kinds of bar code, 9 kinds of default barcode settings, details in page 51 Table 5-4 Factory Default Barcode.
- Can scan inner code and external code, details in page 34, the specification of Bar code printing and scanning
- Barcodes can be divided by use into item barcodes and total barcodes, which are printed in item labels and total labels respectively.
- Factory default barcodes support 5-digits total price and 6-digits total price. Please select the barcode compatible with the POS

Goods Code	Digits of Price	Spec				Suggestion
		001	006	002	007	
Flag Code Using PLU No.	5 Default	1	7	xx	xx00000	x...is the flag code which is reserved for scale in POS system. User could define 0 as a MISC code for PLU Number never equal to 0.
	6	4	8	xx	xx0000	
Flag Code Using PLU Item-Code	5	2	7	xx	xyyyyyy	x...is the flag code which is reserved for scale in POS system. y... is a MISC code for total label. PLU's Item-Code is code in POS system.
	6	5	8	xx	xyyyyy	
No Flag Code Using PLU Item-Code	5	3	7		yyyyyyy	No flag code defined. y... is a MISC code for total label. PLU's Item-Code is code in POS system.
	6	6	8		yyyyyy	

- **If users need special bar code format, please use PC suite or contact with after-service center.**

2.4 Measure Functions

- The scale offers 6 default measure units as kg, gram, ton, lb, 500g, 100g.
- Based on the difference national regulations, some of the measure unit may Not Open. The combinations

and recommended Spec settings are all shown below:

Weight display	U.Price display	Spec					Instructions
		212	211	200	201	208	
kg	/kg	3	0or 3	3	3	3	Default
g	/g	4	0or 4	0	0	0	
g	/100g	4	8	0	0	0	
lb	/lb	6	6	3	3	3	

- Weight precision: The precisions are divided into four levels. Level 0 owns original 1/3000. Level 0 and level 1 are available for commercial users while level 2 and level 3 are only available for industrial users (“*” would be attached in the print of weight). Please refer to Spec213.
- We guarantee the stability and reliability for precision level 0 (1/3000) when the scale leaves factory. And the higher precisions are here to satisfy the need of high definition print for some users, so factory would not guarantee the stability and reliability for higher precision levels for every scale. Please choose the precision prudentially.
- The request Zero-Return for scale print: it’s requested in commercial sales that total weight (sum of net weight and tare weight) of the scale have to return to zero when the scale is going to print the weights of two goods. But for industrial users, this rule could be ignored. Set the value of Spec069 to 2. (“Ind” would be attached in the print of weight).

2.5 Sale Functions

- Users could operate accumulative sales with 4 customers at the same time. Please refer to the Example 4-28 in page 31 for operations.
- Rounding methods could be divided into rounding method for single and rounding method for total. The settings of rounding methods are shown in Spec100 and Spec101.
- Suggest that set the value of Spec100 to 1 if users don’t want the unit “cent” to be displayed in sales.
- Suggest that set the values of Spec100 to 0 and Spec101 to 1 if users want the unit “cent” to be in sale while unit “cent” is not displayed in grand total and print.
- The units’ conversion for PLU default U.Price: set PLU U.Price to 10.00, the unit is 500gram and unit displayed is kg. When transfer PLU10, unit price is displayed as 20.00.
- Units’ conversion for temporary unit price: the scale offers the function of units’ conversion for temporary unit goods and price from 500gram to kg. When U.Price’ display unit is /kg, set the value of Spec210 to 7 and the value of Spec073 to 1 to activate this function. Please refer to the Example 4-6 in page 22, Example 4-20 in page 27.
- No Weigh Sale for Weight PLU: set the value of Spec071 to 1. When the weight returns to zero in weigh sale, input the price and sell the goods at the price you input. Please refer to Example 4-10 in page 23.
- Users can discount on U.Price and T.Price conveniently. The discount methods include discount at a fixed number, discount in subtraction and discount in percentage. Please refer to *Discount Operations* in page 25.
- Users can make a manual weight sale: set the value of Spec077 to non-zero (1, 2 or 3 are ok). Manual

- weight entry can be executed if weight keeps at zero. Refer to the content of <manual weight> on page 1
- Total price Masked before printing: set the value of Spec130 to 1. It will not display current transaction amount till press **【Print】** key
 - Auto record after zero-return set the value of Spec 131 to 1 or 2 (1:unforced 2:forced)., scale still record the transaction in un print condition, convenient to check and audit
 - Auto printing after zero-return: set the value of Spec131 to 3. In weight sale, it will come back to zero in PLU, it will print according to last stable weight.
 - Forced auto printing after zero-return: set the value of Spec131 to 4. In weight sale, when record and valid sale data it will auto printing after zero-return enable while user can not cancel the auto print by quit the PLU.

2.6 Salesman Function

- User could enable salesman login functions. Please refer to Salesman in page 32 and Spec135.

2.7 Report Functions

- Users could print the total reports with time periods of last 32 stat. day, stat. month, stat. quarter or manual time period.
- Users can print the reports for all departments, all classes and part of PLU (below 1000), with a time period of present stat. day, stat. month, stat. quarter or manual time period.
- Please refer to Account Operations in page 63 for the details.

2.8 Sales details

- The scale not only with report print function, but also store the sales record in details, this record can transfer to PC via internet, RS232 or U-disk.
- Because the storage room limit, if operator don't transfer the details often, the scale will delete the old record automatically to save the new records.
- The storage for the sales details is 6000 records (can enlarge into 10000 and more). Each cargo takes one record.

2.9 Network function

- In local area network with a PC or Router enabled DHCP service, scales can connect to network directly without any IP setting.
- If you want to nominate the IP for certain scale, to set Spec150~153 is for 4 segment of IP(Default is 192.168.0.0. When last segment is 0, that means scale connect with Network with way of DHCP. Also means that default way is DHCP), Spec158~161 is for 4 segment of gateway of Network. (Default is 192.168.0.1).
- If the Network for the scale and PC is not in the same one, you can make that with directional connect way. Directional connect include: From PC to scale (should nominate the IP of certain scale on the PC software), and from scale to PC(should set Spec043 as 2----client end mode, and set IP of PC at

Spec154~157)

- Spec166~Spec169 is for the scale's Network Port, change these items may lead to abnormality with Network. Normally please don't modify these 4 items.

2.10 Ethernet Thermal Printer

- Device can connect with Ethernet thermal printer produced by our company, which uses as Remote Printer.
- User can connect Printer and device one-to-one with Crossover Cable. Or connect printers and devices to Ethernet router (with DHCP function) for one-to-many, many-to-one, or many-to-many network.
- User can appoint special print format for Ethernet printer, which may different to printer on the device.

2.11 Software use

- In the CD, there is *software manual*, you can kindly install and use according to the manual.
- The user name of the PC software is **user**, the original password is blank.
- The administer name of the PC software is **admin**, the original password is **200806**.
- You can click *Help---Manual* after run the software, to check the software manual.

3 Fast Prog

Fast prog is the programme operation that draws out some frequently-used programme functions and enables users enter certain frequently-used programme interfaces without selecting in programme interface.

Please make sure system is in the interface of idle sale before transferring fast prog. If system is not in sale operation, pressing **【Sale】** could enter the interface of idle sale. If system is in sale operation, pressing **【Cancel】** for several times could quit sale process and enter the interface of 『Sale Idle』. The sign of the interface of idle sale is that two lights 『Sale』 and 『Sum』 are on. On contrary, if two light of 『Sale』 and 『Single』 are on, system is in sale PLU interface.

3.1 Fast-Prog of PLU

Press **【F-Prog】** + **【PLU】** to enter PLU Fast Prog.

The process of programme is similar with PLU programme in standard programme interface. But users can finish PLU Fast Prog in sale interface.

Example 3-1 Fast-Prog of PLU

Edit PLU10 as a weight PLU with the name Pork-2, U.Price \$30.00/kg, cost \$24.00/kg and tare 0.005g.

Operations	Keys	Display				Remarks
		Tare	Weight/ Count	Change/ U.Price	Single/ Total	
『Sale Idle』		0.000	0.000	0.00	0.00	『Sale』, 『Sum』 on.
PLU Fast Prog	【F-Prog】 + 【PLU】	F23	PLU.00	Not Set	0	『Prog』 on.
			Step No.	Step Info	Object	
PLU Number	【1】【0】	F23	PLU.00	Not Set	10	Number are between 1~9999999
Go to Next	【→】	F23	PLU.01	ICode	0	
Input Item-Code	90001	F23	PLU.01	ICode	90001	ICode is Item-Code, which is usually printed as part of letters on barcode print. If the number of barcodes is default 2/5 or other custom numbers, ICode are printed as a part of barcodes. Please see details in chapter Barcode.
Go to Next	【→】	F23	PLU.03	Unit	0	
Set as weight PLU	【1】	F23	PLU.03	Unit	1	【0】 , 【1】 : default weight unit; 【2】 : default count unit; 【3】 : kg weight unit; 【4】 : g weight unit; 【5】 : ton weight unit; 【6】 : lb weight unit; 【7】 : 500g weight unit; 【8】 : 100g weight unit; Please see details in unit chapter. Default weight unit mean the unit used for display. And it is suggested for weight PLU.
Go to Next	【→】	F23	PLU.04	Price	0.00	

Set U.Price	【3】【0】【00】	F23	PLU.04	Price	30.00	Preset U.Price in sale. Don't have to input it. Users can temporarily input it in sale.
Go to Next	【→】	F23	PLU.05	Cost	0.00	
Set cost	【2】【4】【00】	F23	PLU.05	Cost	24.00	The cost is used to calculate the profits. Don't have to input it.
Go to Next	【→】	F23	PLU.06	Tare	0.000	
Set Tare	【5】	F23	PLU.06	Tare	0.005	When transferring PLU, it's preset tare. Don't have to input it.
Go to Next	【→】	F23	PLU.14	Name	OK-Edit	Input the names of goods.
Set name	【Confirm】	En-1	0			
Clear Original Text	【End】	EN-1	0			In consideration of there was a text, we suggest users press 【End】 before editing. If editing in the original text, users could use【←】【→】 to move the position of cursor.
P	【Shift】【p/P】	EN-1	1	P		
o r k	【o/O】【r/R】 【k/K】	EN-1	4	rk		
-	【-】	EN-1	5	k-		
Input number 2	【2】	En-1	6	-2		
Save edited text	【Amend】	F23	PLU.14	Name	OK-Edit	This 【Amend】 is to save text edit in buffers instead of PLU. Please pay attention: If users need save it in PLU, users need to press 【Amend】 again as the step below.
Go to next	【→】	F23	PLU.26	PS-UD	0	If to print the shelf life date
Print shelf date	【1】	F23	PLU.26	PS-UD	1	0: Don't print PLU 31 invalid 1: Print. Continiune to set shelf days in PLU.31
Go to next	【→】	F23	PLU.31	PC-UD	0	Shelf days. 0 means intraday valid, followed like this.
Input shelf days	【→】	F23	PLU.31	PC-UD	3	If all cargo for one scale use same shelf days, use Spec105 & Spec106
.....						If other steps are still to be edited, users can use 【←】【→】 to switch steps.
Save edited PLU	【Amend】	F23	PLU.00	Not Set	0	PLU10 is saved.
Return to sale	【Cancel】	0.000	0.000	0.00	0.00	【Sale】 , 【Sum】 on

Note 1 Except the parts which have been instructed, meaning of the other words are listed in *List of Programme Interface* in page 37.

Note 2 PLU fast-prog is forbidden when Spec080=0.

Note 3 Before you move to next step, the display of E1.01 Data Invalid means that the programme data you input is invalid.

Note 4 The xx in PLU.xx means the content in the data which is marked with the number of xx in PLU fast

prog.

Note 5 Xx is not continuous when users press **【←】** and **【→】** to select the programme content. There are two reasons. First reason is that the content in that part is meaningless. For example, tare is not present in count PLU programme. The second reason is that the content in that part is seldom used and has been set as non-programme content (Skip) in P3.01 and P3.02. Users could change that setting for personal usage. Please refer to corresponding chapters for details.

3.2 Fast-Prog of Shortcut Key for PLU

Press **【F-Prog】** + **【SCxx】** to enter PLU shortcut key programme. **【SCxx】** could be one of **【SC1】** ~ **【SC63】**. After pressing one key, Users can input the PLU which the pressed key appoints to. Then press **【Amend】** to save and exit.

Users can save without exit if they would like to go on to amend other shortcut keys. Press **【Confirm】** to save the change and press another **【SCxx】** to amend. The number of input PLU must exist. User can select existing PLU by pressing **【↑】** **【↓】**. The process of programme is similar with scPLU programme in standard programme interface. Please refer to the process shown below.

Example 3-2 Fast-Prog of Shortcut Key for PLU. Amend a shortcut key.

Operations	Keys	Display				Remarks
		Tare	Weight/ Count	Change/ U.Price	Single/ Total	
〔Sale Idle〕		0.000	0.000	0.00	0.00	〔Sale〕, 〔Sum〕 on.
PLU shortcut key programme, and the object is SC1	【F-Prog】 + 【SC1】	F14	scPLU	0-01	0	〔Prog〕 on.
				Key No.	PLU No.	
Input PLU number	【1】【0】	F14	scPLU	0-01	10	
Save directly	【Amend】	0.000	0.000	0.00	0.00	Save to the scale. 〔Sale〕, 〔Sum〕 on

Note 1 When Spec081=0, PLU shortcut-key fast-prog is forbidden.

Example 3-3 Fast-Prog of Shortcut Key for PLU. Amend two or more shortcut keys.

Operations	Keys	Display				Remarks
		Tare	Weight/ Count	Change/ U.Price	Single/ Total	
〔Sale Idle〕		0.000	0.000	0.00	0.00	〔Sale〕, 〔Sum〕 on.
PLU shortcut key programme, and the object is SC1	【F-Prog】 + 【SC1】	F14	scPLU	0-01	0	〔Prog〕 on.
				Key No.	PLU No.	
Input PLU number	【1】【0】	F14	scPLU	0-01	10	
Confirm input	【Confirm】	F14	scPLU	-----	-----	Save to temporary buffer.
Set SC2	【SC2】	F14	scPLU	0-02	0	
Input PLU number	【1】【1】	F14	scPLU	0-02	11	
Confirm input	【Confirm】	F14	scPLU	-----	-----	Save to temporary buffer.
Set Shift+SC1	【Shift】【SC1】	F14	scPLU	1-01	0	
Input PLU number	【1】【0】【0】	F14	scPLU	1-01	100	

Confirm input	【Confirm】	F14	scPLU	-----	-----	Save to temporary buffer. The last confirm can be skipped. Press 【Amend】 directly.
Save	【Amend】	0.000	0.000	0.00	0.00	Save to the scale. [[Sale]], [[Sum]] on.

Note 1 When Spec081=0, PLU shortcut key fast prog is forbidden.

3.3 Fast-Prog of Spec Parameters

Press **【F-Prog】** + **【Prog】** to enter Spec parameters fast prog.

Please select the number you want to edit by pressing **【←】****【→】**. The second window shows the number of Spec which is being edited. The third window shows current parameters configuration. The fourth window shows the data which has been edited by users.

Spec data parameters are made up of some number data. Refer to Definitions of Spec data parameters in page 73 in order to understand functions of these parameters.

Press **【Amend】** to save and quit, or press **【Cancel】** to quit without saving. The process of programme is similar with Spec programme in standard programme interface. For details, please refer to the process shown below.

Here, we are going to amend Spec000 to 2, Spec002 to 77 and Spec040 to 99. We would present the processes without discussing on the parameters we actually amend and their meanings.

Example 3-4 Fast-Prog of Spec Parameters

Operations	Keys	Display				Remarks
		Tare	Weight/ Count	Change/ U.Price	Single/ Total	
[[Sale Idle]]		0.000	0.000	0.00	0.00	[[Sale]], [[Sum]] on.
Spec fast prog	【F-Prog】 + 【Prog】	F12	SP.000	1	1	[[Prog]] on.
			Spec No.	Origin Set	Current Set	
Change to 2	【2】	F12	SP.000	1	2	
Enter Spec002	【→】 【→】	F12	SP.002	0	0	Using 【←】 【→】 can only get to amend items in Spec amend level 0.
Change to 77	【7】 【7】	F12	SP.002	0	77	
Choose steps directly	【×】		Input	1 - 1	0	
Input step 40	【4】 【0】		Input	1 - 1	40	The input number of step must be in Spec amend level 0 or 1. If not, the step cannot be reached.
Confirm step	【Confirm】	F12	SP.040	0	0	
Change to 99	【9】 【9】	F12	SP.040	0	99	
Save and exit	【Amend】	0.000	0.000	0.00	0.00	[[Sale]], [[Sum]] on.

Note 1 Spec fast-prog programme is forbidden when Spec082 = 0.

Note 2 Refer to Definitions of Spec data parameters in page 73 to know the definitions of data parameters .

Note 3 Read the definition of the parameter before you change it. And don' t change any unknown

parameters in Spec programme.

Note 4 xxx in SP.xxx means the number of the data content in Spec programme.

Note 5 xxx is not continuous when users press **【←】** and **【→】** to select the programme content. Users can only select Spec in level 0 by pressing **【←】** and **【→】**. You have to input corresponding numbers after pressing **【×】** to change Spec in level 1. And users cannot reach Spec in level 2 and level 3 because their data are involved with some specifications in measurement and other hardware fields.

3.4 Fast-Prog of Unit price

After transfer PLU, press **【-@】** or **【@Price】** to fast change this PLU's price

Example 3-5 Fast-Prog of unit price (Spec083=1)

Operations	Keys	Display				Remarks
		Tare	Weight/ Count	Change/ U.Price	Single/ Total	
『Sale Idle』		0.000	0.000	0.00	0.00	『Sale』, 『Sum』 on
Transfer PLU10	【1】【0】【PLU】	0.000	0.000	5.00	0.00	
Input the amended price	【6】【0】【0】	0.000	0.000	6.00	0.00	
Amend price	Long press 【-@】	0.000	0.000	6.00	0.00	PLU10's default price change to 6.00
Exit	【Cancell】	0.000	0.000	0.00	0.00	『Sale』, 『Sum』 on.

Note 1 When Spec083=1, the step to amend unit price please refer to step 2: first judge whether the input price in discount section or not, then set the accordant price as PLU's default price

Example 3-6 Fast-Prog of unit price (Spec083=2)

Operations	Keys	Display				Remarks
		Tare	Weight/ Count	Change/ U.Price	Single/ Total	
『『Sale Idle』』		0.000	0.000	0.00	0.00	『Sale』, 『Sum』 on
Transfer PLU10	【1】【0】【PLU】	0.000	0.000	5.00	0.00	
Input the amended price	【6】【0】【0】	0.000	0.000	6.00	0.00	
Amend price	【-@】	0.000	0.000	6.00	0.00	PLU10's default price change to 6.00
Exit	【Cancell】	0.000	0.000	0.00	0.00	『Sale』, 『Sum』 on.

Note 1 When Spec083=2, during the unit price amend, it will not judge the rationality of the input price and directly save as PLU's default price

4 Sale Operations

4.1 Transfer and Lock of PLU

PLU9999999 is temporary by-weight goods (Spec93), PLU9999998 is temporary by-count goods (Spec94), PLU9999997 is service charge (Spec95), user can use all other 7 digits PLU.

4.1.1 Transfer by Using PLU Number

Example 4-1 Use PLU Number to Transfer Weight PLU

Transfer PLU10, assuming PLU10 is a weight PLU with U.Price \$2.00/kg and tare 0.100kg.

Operations	Keys	Display				Remarks
		Tare	Weight/ Count	Change/ U.Price	Single/ Total	
〔Sale Idle〕		0.000	0.000	0.00	0.00	〔Sale〕 , 〔Sum〕 on.
Input number	【1】【0】	0.000	0.000	0.10	0.00	
Transfer PLU	【PLU】	0.100	-0.100	2.00	0.00	〔U.Price〕 , 〔Single〕 on.
Clear current PLU	【Cancel】	0.000	0.000	0.00	0.00	

Example 4-2 Use PLU Number to Transfer Count PLU

Transfer PLU11, assuming PLU11 is count PLU with U.Price \$5.00/pc.

Operations	Keys	Display				Remarks
		Tare	Weight/ Count	Change/ U.Price	Single/ Total	
〔Sale Idle〕		0.000	0.000	0.00	0.00	〔Sale〕 , 〔Sum〕 on.
Input number	【1】【1】	0.000	0.000	0.11	0.00	
Transfer PLU	【PLU】			5.00	0.00	〔U.Price〕 , 〔Single〕 on.
Clear current PLU	【Cancel】	0.000	0.000	0.00	0.00	

4.1.2 Transfer by Using PLU Shortcut Keys

Example 4-3 Use PLU Shortcut Keys to Transfer Weight PLU

Transfer SC1, assuming SC1=PLU10 and it is a weight PLU with U.Price \$2.00/kg and tare 0.100kg.

Operations	Keys	Display				Remarks
		Tare	Weight/ Count	Change/ U.Price	Single/ Total	
〔Sale Idle〕		0.000	0.000	0.00	0.00	〔Sale〕 , 〔Sum〕 on.
Input shortcut key	【SC1】	0.100	-0.100	2.00	0.00	〔U.Price〕 , 〔Single〕 on.
Clear current PLU	【Cancel】	0.000	0.000	0.00	0.00	〔Sum〕 on

Example 4-4 Use PLU Shortcut Keys to Transfer Count PLU

Transfer SC2, assuming SC2=PLU11 and it is count PLU with U.Price \$5.00/pc.

Operations	Keys	Display				Remarks
		Tare	Weight/ Count	Change/ U.Price	Single/ Total	
〔Sale Idle〕		0.000	0.000	0.00	0.00	〔Sale〕 , 〔Sum〕 on.
Input shortcut key	【SC2】			5.00	0.00	〔U.Price〕 , 〔Single〕 on.
Clear current PLU	【Cancel】	0.000	0.000	0.00	0.00	〔Sum〕 on

4.1.3 Transfer Temporary Weight PLU

Example 4-5 Transfer Temporary Weight PLU

Operations	Keys	Display				Remarks
		Tare	Weight/ Count	Change/ U.Price	Single/ Total	
『Sale Idle』		0.000	0.000	0.00	0.00	[[Sale]], [[Sum]] on.
Input Unit Price	【1】【3】【0】	0.000	0.000	1.30	0.00	
Set as a temporary weight PLU,	【T-Sale】	0.000	0.000	1.30	0.00	[[U.Price]], [[Single]] on.
Clear current PLU	【Cancel】	0.000	0.000	0.00	0.00	[[Sum]] on.

Note 1 Temporary weight PLU could be converted into count PLU if users press **【×】** or the weight is zero.

Note 2 Temporary PLU's number are decided by Spec093 (the default is 9999999)

Example 4-6 Transfer Temporary Weight PLU with a Unit Conversion of the U.Price.

Operations	Keys	Display				Remarks
		Tare	Weight/ Count	Change/ U.Price	Single/ Total	
『Sale Idle』		0.000	0.000	0.00	0.00	[[Sale]], [[Sum]] on.
Input Unit Price	【1】【7】【0】	0.000	0.000	1.70	0.00	
Set as a temporary weight PLU, and convert its unit.	【T-Sale】	0.000	0.000	3.40	0.00	[[U.Price]], [[Single]] on. Convert unit between 500g/kg
Clear current PLU	【Cancel】	0.000	0.000	0.00	0.00	[[Sum]] on.

Note 1 Assume temporary weight unit is 500g (Spec210) and the unit of scale is kg. After input the U.Price of 1.70 and press **【T-Sale】**, the U.Price is converted into 3.40. That means the conversion of the unit between 500g and kg is done.

4.1.4 Transfer Temporary Count PLU

Example 4-7 Temporary PLU number is decided by Spec094(default 9999998)

Operations	Keys	Display				Remarks
		Tare	Weight/ Count	Change/ U.Price	Single/ Total	
『Sale Idle』		0.000	0.000	0.00	0.00	[[Sale]], [[Sum]] on.
Input Unit Price	【1】【7】【0】	0.000	0.000	1.70	0.00	
Set as a temporary count PLU	【×】		1	1.70	1.70	[[U.Price]], [[Single]] on.
Clear current PLU	【Cancel】	0.000	0.000	0.00	0.00	[[Sum]] on.

4.2 Manual Goods Sale

4.2.1 Sale and Print of Single Weight Goods

Example 4-8 Sale for Single Weight goods

Sell 1 kg PLU10 goods. Assume PLU10 is a weight PLU with U.Price is \$2.00/kg and tare is 0.100kg.

Operations	Keys	Display				Remarks
		Tare	Weight/ Count	Change/ U.Price	Single/ Total	
〔Sale Idle〕		0.000	0.000	0.00	0.00	〔Sale〕 , 〔Sum〕 on.
Transfer PLU10	【1】【0】【PLU】	0.100	-0.100	2.00	0.00	〔U.Price〕 , 〔Single〕 on.
Put on a weight		0.100	0.900	2.00	1.80	
Print	【Print】	0.000	0.000	0.00	0.00	Execute print.

Note 1 Two qualifications are indispensable when directly print without accumulating: 1. Current accumulative buffer is empty, 2. The value of Spec060 is not 3 (forbid cashing mode with default zero change).

Note 2 The system would have to wait for several seconds if users sell the weigh goods when the display of weight is not stable. If the display of weight is stable in the waiting time, system would sell the goods according to the operations. Please refer to Spec151 about the waiting time.

4.2.2 Sale and Print of Single Count Goods

Example 4-9 Sale and Print for Single Count goods

Sell 5pcs PLU11. Assume PLU11 is count PLU with U.Price is \$5.00/pc.

Operations	Keys	Display				Remarks
		Tare	Weight/ Count	Change/ U.Price	Single/ Total	
〔Sale Idle〕		0.000	0.000	0.00	0.00	〔Sale〕 , 〔Sum〕 on.
Transfer PLU11	【1】【1】【PLU】			5.00	5.00	〔U.Price〕 , 〔Single〕 on.
Input PLU11 amount	【×】【5】		5	5.00	25.00	
Print	【Print】	0.000	0.000	0.00	0.00	Execute print.

Note 1 Two qualifications are indispensable when directly print without accumulating: 1. Current accumulative buffer is empty, 2. The value of Spec060 is not set to be 3 (orbid cashing mode with default zero change).

4.2.3 No Weigh Sale for Weight Goods

Example 4-10 No Weigh Sale for Weight PLU

Operations	Keys	Display				Remarks
		Tare	Weight/ Count	Change/ U.Price	Single/ Total	
〔Sale Idle〕		0.000	0.000	0.00	0.00	〔Sale〕 , 〔Sum〕 on.
Transfer PLU10	【1】【0】【PLU】	0.100	-0.100	2.00	0.00	〔U.Price〕 , 〔Single〕 on.
Input T.Price of goods	【3】【8】【0】	0.100	-0.100	3.80	0.00	
Print	【Print】	0.000	0.000	0.00	0.00	Execute print. Or press 【Confirm】 to do cumulate operations.

Note 1 To execute no weigh sale, the value of Spec071 needs to be set to 1 while the default value is 0.

Note 2 Temporary goods' no weigh sale is not restricted by Spec071. And it could automatically convert to count sale for temporary count goods.

4.2.4 Sale and Print for Different Kinds of Goods (No Cashing Mode)

Example 4-11 Sale and Print for Different Kinds of Goods (No Cashing Mode)

Sell 1kg PLU10 and 5pcs PLU11. Assume PLU10 is weight PLU with U.Price \$2.00/kg and tare 0.100kg, PLU11 is count PLU with U.Price \$5.00/pc.

Operations	Keys	Display				Remarks
		Tare	Weight/ Count	Change/ U.Price	Single/ Total	
〔Sale Idle〕		0.000	0.000	0.00	0.00	〔Sale〕 , 〔Sum〕 on.
Transfer PLU10	【1】【0】【PLU】	0.100	-0.100	2.00	0.00	〔U.Price〕 , 〔Single〕 on.
Put goods PLU10 on		0.100	0.900	2.00	1.80	
Confirm a goods	【Confirm】	0.000	1.000	0.00	1.80	〔Sum〕 on.
Take goods PLU10 off		0.000	0.000	0.00	1.80	
Transfer PLU11	【1】【1】【PLU】			5.00	5.00	〔U.Price〕 , 〔Single〕 on.
Input the number of PLU11	【×】【5】		5	5.00	25.00	
Confirm a goods	【Confirm】	0.000	0.000	0.00	26.80	〔Sum〕 on.
Print	【Print】	0.000	0.000	0.00	0.00	Execute print.

Note 1 Users can execute no cashing mode when the value of Spec60 is 0 or 1.

4.2.5 Sale and Print for Different Kinds of Goods (Cashing Mode, Input Payment)

Example 4-12 Sale and Print for Different Kinds of Goods (Cashing Mode, Input Payment)

Sell 1kg PLU10 and 5pcs PLU11. Assume PLU10 is weight PLU with U.Price \$2.00/kg and tare 0.100kg, PLU11 is count PLU with U.Price \$5.00/pc. Payment is \$30.

Operations	Keys	Display				Remarks
		Tare	Weight/ Count	Change/ U.Price	Single/ Total	
〔Sale Idle〕		0.000	0.000	0.00	0.00	〔Sale〕 , 〔Sum〕 on.
Transfer PLU10	【1】【0】【PLU】	0.100	-0.100	2.00	0.00	〔U.Price〕 , 〔Single〕 on.
Put goods PLU10 on		0.100	0.900	2.00	1.80	
Confirm a goods	【Confirm】	0.000	1.000	0.00	1.80	〔Sum〕 on.
Take goods PLU10 off		0.000	0.000	0.00	1.80	
Transfer PLU11	【1】【1】【PLU】			5.00	5.00	〔U.Price〕 , 〔Single〕 on.
Input the number of PLU11	【×】【5】		5	5.00	25.00	
Confirm a goods	【Confirm】	0.000	0.000	0.00	26.80	〔Sum〕 on.
Input payment amount	【3】【0】【00】	0.000	0.000	30.00	26.80	
Print	【Print】			3.20	26.80	〔Change〕 , 〔Sum〕 on. Execute print.
		0.000	0.000	0.00	0.00	Press any key to return. Or wait several seconds to exit according to the system setting of Spec066.

Note 1 Cashing mode is available and change interface is displayed when the value of Spec060 is 1, 2, or 3.

4.2.6 Sale and Print for Different Kinds of Goods (Cashing Mode, Payment Equal to Price)

Example 4-13 Sale and Print for Different Kinds of Goods (Cashing Mode, Payment Equal to Price)

Sell 1kg PLU10 and 5pcs PLU11. Assume PLU10 is weight PLU with U.Price \$2.00/kg and tare 0.100kg, PLU11 is count PLU with U.Price \$5.00/pc. Payment is \$26.80.

Operations	Keys	Display				Remarks
		Tare	Weight/ Count	Change/ U.Price	Single/ Total	
〔Sale Idle〕		0.000	0.000	0.00	0.00	〔Sale〕 , 〔Sum〕 on.
Transfer PLU10	【1】【0】【PLU】	0.100	-0.100	2.00	0.00	〔U.Price〕 , 〔Single〕 on.
Put goods PLU10 on		0.100	0.900	2.00	1.80	
Confirm a goods	【Confirm】	0.000	1.000	0.00	1.80	〔Sum〕 on.
Take goods PLU10 off		0.000	0.000	0.00	1.80	
Transfer PLU11	【1】【1】【PLU】			5.00	5.00	〔U.Price〕 , 〔Single〕 on.
Input the number of PLU11	【×】【5】		5	5.00	25.00	
Confirm a goods	【Confirm】	0.000	0.000	0.00	26.80	〔Sum〕 on.
If payment equal to price, don't input.		0.000	0.000	0.00	26.80	
Print	【Print】			0.00	26.80	〔Change〕 , 〔Sum〕 on. Execute print.
		0.000	0.000	0.00	0.00	Press any key to return. Or wait several seconds to exit according to the system setting of Spec066.

Note 1 Cashing mode without input the amount of payment is available and change interface is displayed when the value of Spec060 is set to 2.

4.3 Discount Operations

4.3.1 U.Price Discount

The data after discount should be within the discountable area. If the data exceeds the area, discount operation would fail.

Example 4-14 Execute Discount in Subtraction

Discount in U.Price: discount at the subtraction of \$0.10/kg. Assume that PLU10 is weight PLU with U.Price \$2.00/kg and tare 0.100kg.

Operations	Keys	Display				Remarks
		Tare	Weight/ Count	Change/ U.Price	Single/ Total	
〔Sale Idle〕		0.000	0.000	0.00	0.00	〔Sale〕 , 〔Sum〕 on.
Transfer PLU10	【1】【0】【PLU】	0.100	-0.100	2.00	0.00	〔U.Price〕 , 〔Single〕 on.
Input discount data	【1】【0】	0.100	-0.100	0.10	0.00	
Discount in subtraction	【-Num】	0.100	-0.100	1.90	0.00	〔Discount〕 on.

Example 4-15 Execute Discount at a Fixed Number

Discount in U.Price: discount the U.Price to \$1.80/kg. Assume that PLU10 is weight PLU with U.Price

\$2.00/kg and tare 0.100kg.

Operations	Keys	Display				Remarks
		Tare	Weight/ Count	Change/ U.Price	Single/ Total	
〔Sale Idle〕		0.000	0.000	0.00	0.00	〔Sale〕 , 〔Sum〕 on.
Transfer PLU10	【1】【0】【PLU】	0.100	-0.100	2.00	0.00	〔U.Price〕 , 〔Single〕 on.
Input discount data	【1】【8】【0】	0.100	-0.100	1.80	0.00	
Discount at a fixed number	【-@】	0.100	-0.100	1.80	0.00	〔Discount〕 on.

4.3.2 T.Price Discount

The operations of T.Price discount and U.Price discount are the same. Under the condition that PLU is not transferred and with accumulative buffers, execute discount operation is to discount on T.Price. The processes are not repeated here. The limit of discount on T.Price is a accumulative value of U.Price discount limits of all goods.

4.3.3 ± % price

【±%】 key and 【-%】 ket are the same key. When ±% price, the data object is floating-point decimal fraction. For the same 5% discount, if input data is two digit decimal fraction, you need input 500; if with three digit decimal fraction, then input 5000. you can long press 【Shift】 or 【Fast prog】 + 【Shift】 to change the decimal point site.

Example 4-16 Input data to execute ± % price

U.Price-%price: at the percentage of 95%, as $\times \frac{100.00 - 5.00}{100.00}$. Assume that PLU10 is weight PLU with

U.Price \$2.00/kg and tare 0.100kg.

Operations	Keys	Display				Remarks
		Tare	Weight/ Count	Change/ U.Price	Single/ Total	
〔Sale Idle〕		0.000	0.000	0.00	0.00	〔Sale〕 , 〔Sum〕 on.
Transfer PLU10	【1】【0】【PLU】	0.100	-0.100	2.00	0.00	〔U.Price〕 , 〔Single〕 on.
Input discount data	【5】【00】	0.100	-0.100	5.00	0.00	
Discount in percentage	【±%】	0.100	-0.100	1.90	0.00	〔Discount〕 on.

Note 1 Default percentage discount is subtraction discount(Spec113=0) , if need to change the default discount to additive, change Spec113=1

Example 4-17 Enterinterface and execute ± %price

Unit price+%price,charge 10% more.Assume that PLU10 is weight PLU with U.Price \$2.00/kg and tare 0.100kg.

Operations	Keys	Display				Remarks
		Tare	Weight/ Count	Change/ U.Price	Single/ Total	
〔Sale Idle〕		0.000	0.000	0.00	0.00	〔Sale〕 , 〔Sum〕 on.
Transfer PLU10	【1】【0】【PLU】	0.100	-0.100	2.00	0.00	〔U.Price〕 , 〔Single〕 on.
Enter ± %price interface	【±%】			Sub-P	- 0.00	without any number before 【±%】 Sub-P means it is -%

Amend to +%	【 ±% 】			Add-P	0.00	
Input 10%	【1】【0】【00】			Add-P	10.00	
Execute +%price	【 Confirm 】	0.100	-0.100	2.20	0.00	[[Discount]] on.

Note 1 Press 【 ±% 】 repeatedly to amend the operation symbol to '+' or '-'.

Example 4-18 Directly execute default ± %price(Spec114)

Unit price+%price(Spec113=1) , charge additional 20%(Spec114=20) . Assume that PLU10 is weight PLU with U.Price \$2.00/kg and tare 0.100kg.

Operations	Keys	Display				Remarks
		Tare	Weight/ Count	Change/ U.Price	Single/ Total	
[[Sale Idle]]		0.000	0.000	0.00	0.00	[[Sale]] , [[Sum]] on.
Transfer PLU10	【1】【0】【PLU】	0.100	-0.100	2.00	0.00	[[U.Price]] , [[Single]] on.
Execute default ± %price	【 ±% 】	0.100	-0.100	2.40	0.00	without any number before 【 ±% 】 [[Discount]] on.

Note 1 When execute default ± %price, the +/- are decided by Spec113, default price is decided by Spec114

4.3.4 Auto Discount

When goods are working on auto discount, the price of activated PLU would change in real-time according to the settings and system would shield any actions of manual change on the price.

Assume PLU20 is at the U.Price \$10.00/kg. U.Price goes to \$9.00/kg when sale weight is more than 1kg and U.Price goes to \$8.00/kg when sale weight is more than 2kg. The change of U.Price of this PLU is shown below:

Example 4-19 Auto Discount

Operations	Keys	Display				Remarks
		Tare	Weight/ Count	Change/ U.Price	Single/ Total	
[[Sale Idle]]		0.000	0.000	0.00	0.00	[[Sale]] , [[Sum]] on.
Transfer PLU20	【2】【0】【PLU】	0.000	0.000	10.00	0.00	[[U.Price]] , [[Single]] on.
Put weight 1.5kg		0.000	1.500	9.00	13.50	[[Discount]] on.
Add weight 1kg		0.000	2.500	8.00	20.00	[[Discount]] on.
Take off all weight and put on weight 0.5kg.		0.000	0.500	10.00	5.00	[[Discount]] off.

Note 1 All details about the auto discount setting of PLU, please read definitions of auto discount settings in

List of Programme Interface on page 37 and Spec115 carefully. Suggest users edit the content on PC.

4.3.5 Unit Conversion of Temporary U.Price

Example 4-20 Unit Conversion of Temporary U.Price

Operations	Keys	Display				Remarks
		Tare	Weight/ Count	Change/ U.Price	Single/ Total	
[[Sale Idle]]		0.000	0.000	0.00	0.00	[[Sale]] , [[Sum]] on.
Transfer PLU10	【1】【0】【PLU】	0.100	-0.100	2.00	0.00	[[U.Price]] , [[Single]] on.

Input a Temporary U.Price with the unit of 500g	【1】【8】【0】	0.100	-0.100	1.80	0.00	
Unit conversion	【T-Sale】	0.100	-0.100	3.60	0.00	

Note 1 Spec210 is 7 (500g), and kg is the measure unit of the scale.

Note 2 Spec073 is 1: Put 【T-Sale】 into use of 【Unit Conversion】 .

4.4 Setting and Lock of Tare

4.4.1 Weight Tare

Example 4-21 Weight Tare

Operations	Keys	Display				Remarks
		Tare	Weight/Count	Change/U.Price	Single/Total	
〔Sale Idle〕		0.000	0.000	0.00	0.00	〔Sale〕 , 〔Sum〕 on.
Put on tare object		0.000	0.050	0.00	0.00	
Tare	【Tare】	0.050	0.000	0.00	0.00	
Take off tare object		0.050	-0.050	0.00	0.00	
Cancel tare	【Tare】	0.000	0.000	0.00	0.00	

Note 1 If users need to cancel tare, current total weight should be 0 and users do not input any number.

4.4.2 Number Tare

Example 4-22 Number Tare

Operations	Keys	Display				Remarks
		Tare	Weight/Count	Change/U.Price	Single/Total	
〔Sale Idle〕		0.000	0.000	0.00	0.00	〔Sale〕 , 〔Sum〕 on.
Input tare	【3】【2】	0.000	0.000	0.32	0.00	
tare	【Tare】	0.032	-0.032	0.00	0.00	
Cancel tare	【Tare】	0.000	0.000	0.00	0.00	

Note 1 Spec067 is 0: Number tare is forbidden

Note 2 Spec067 is 1: Use absolute value as tare. For example, when the tare definition is 0.001 and input is 0.32, tare is 0.032.

Note 3 Spec067 is 2: Use floating-point values as tare. For example, input 0.32 and after tare users would get 0.320.

Note 4 When there are numbers in input window and total weight is not 0, weight tare is the priority.

4.4.3 Lock and Unlock of Tare

Example 4-23 Tare Lock and Unlock

Operations	Keys	Display				Remarks
		Tare	Weight/Count	Change/U.Price	Single/Total	
Lock tare	Long Press 【Tare】					〔Lock Tare〕 on
Other operations						
Unlock tare	Long Press 【Tare】					〔Lock Tare〕 off

Note 1 When you long press **【Tare】** , you can hear one beep first (beep for correctness or error) . Hold pressing for 4 seconds you will hear the beep for correctness.

Note 2 Once tare locked, it cannot be changed or cleared automatically. Only manual tare can change tare.

Note 3 Once tare locked, it cannot be unlocked unless users unlock tare manually.

4.5 Special sale mode

Except general sale mode, scale also with other 4 special sale mode: batch print model, pre-packing mode, lock PLU mode, auto print mode

4.5.1 Enter and Exit of Special sale Mode

Example 4-24 Single key select of sale mode

Operations	Keys	Display				Remarks
		Tare	Weight/ Count	Change/ U.Price	Single/ Total	
『Sale Idle』						
Enter Auto Mode	【Auto Mode】					
Exit Auto Mode	【Auto Mode】					
Enter prepack mode	【Prepack Mode】					
Exit prepack mode	【Prepack Mode】					
Enter auto print mode	【Auto print】					
Exit auto print mode	【Auto print】					

Note 1 **【Auto Mode】** key related mode are decided by Spec78

Note 2 Only for super market version scale with the **【Prepack Mode】** **【Auto print】** and **【lock PLU】** key

Note 3 Under one special mode, press special mode key will exit present mode and back to general sale mode

Example 4-25 Interface select sale mode

Operations	Keys	Display				Remarks
		Tare	Weight/ Count	Change/ U.Price	Single/ Total	
『Sale Idle』						
Enter Mode select interface	Long press 【Auto Mode】			Mode 0	Normal	【0】 : General mode 【1】 : Batch print mode 【2】 : Prepack mode 【3】 : Lock PLU mode 【4】 : Auto print mode
Select auto print mode	【4】					Can use 【←】 【→】 【COntfirm】 to select mode
『Auto print mode』						

Note 1 Menu of sale mode selection enable by Spec79

4.5.2 Sale under batch print mode

Example 4-26 Batch Print mode

Batch print mode. Assume PLU11 is weight PLU with U.Price \$2.00/kg and tare 0.100kg.

Operations	Keys	Display				Remarks
		Tare	Weight/ Count	Change/ U.Price	Single/ Total	
〔Sale Idle〕		0.000	0.000	0.00	0.00	〔Sale〕 , 〔Sum〕 on.
Enter mode select	Long press 【Auto Mode】			Mode 0	Normal	
Enter batch print mode	【1】	0.000	0.000	0.00	0.00	〔Auto Mode〕 on
Transfer PLU11	【1】【1】【PLU】			5.00	5.00	〔U.Price〕 , 〔Single〕 on.
Input quantity	【×】【5】		5	5.00	25.00	If number is 1, omit this step
Confirm sale object	【Print】		Input	Count	0	
Input the number of print copies	【1】【0】		Input	Count	10	
Confirm the number	【Confirm】					
Print 10 copies						Press 【Cancel】 to exit print in midway.
Print ends		5	5.00	5.00		
Exit quantity input			5.00	25.00		
Exit PLU	0.000	0.000	0.00	0.00	0.000	〔Sum〕 on.
Exit Auto Mode	0.000	0.000	0.00	0.00	0.000	〔Auto Mode〕 off.

Note 1 Under Batch print mode, user can accumulate, after accumulate , press 【Print】 select the print times

4.5.3 Sale under prepack mode (only for weight PLU)

Example 4-27 Prepack mode(only for weight PLU)

Prepack mode for weight PLU. Assume PLU10 is weight PLU with U.Price \$2.00/kg and tare 0.100kg.

Operations	Keys	Display				Remarks
		Tare	Weight/ Count	Change/ U.Price	Single/ Total	
〔Sale Idle〕		0.000	0.000	0.00	0.00	〔Sale〕 , 〔Sum〕 on.
Enter mode select	Long press 【Auto Mode】			Mode 0	Normal	
Enter prepack mode	【1】	0.000	0.000	0.00	0.00	〔Auto Mode〕 , 〔lock PLU〕 on
Transfer PLU10	【1】【0】【PLU】	0.100	-0.100	2.00	0.00	〔U.Price〕 , 〔Single〕 on.
Put goods PLU10 on		0.100	0.900	2.00	1.80	
After weight is stable.		0.100	0.900	0.00	1.80	Print automatically.
Take goods PLU10 off		0.100	-0.100	0.00	0.00	
Put goods PLU10 on		0.100	1.900	2.00	3.80	
After weight is stable.		0.100	1.900	0.00	0.00	Print automatically.
Take goods PLU10 off		0.100	-0.100	0.00	0.00	
.....						
Exit PLU	【Cancel】					〔Sum〕 on.
Exit Auto Mode	【Auto Mode】					〔Auto Mode〕 , 〔lock PLU〕 off.

Note 1 Pre-packing enable if Spec078 is set to 2.

4.5.4 Sale under Lock PLU mode

Under lock PLU mode, cargo cannot be accumulated and after finish the sale, will not exit the present PLU automatically.

4.5.5 Auto print mode (only for weight PLU)

Under auto mode, when the weight is stable, print automatically.

4.6 Operations of Sale Buffers

4.6.1 Switch of Sale Buffers

Example 4-28 Switch of Sale Buffers

Operations	Keys	Display				Remarks
		Tare	Weight/ Count	Change/ U.Price	Single/ Total	
『Sale Idle』 Default buffer V1		0.000	0.000	0.00	0.00	[[Sale]], [[Sum]] on. [[V1]] glittering.
Transfer PLU10	【1】【0】【PLU】	0.100	-0.100	2.00	0.00	[[U.Price]], [[Single]] on.
Put goods PLU10 on		0.100	0.900	2.00	1.80	
Confirm a goods	【Confirm】	0.000	1.000	0.00	1.80	[[Sum]] on.
Service other customers, for current customer delay checking out					
Switch buffer V2	【V2】	0.000	0.000	0.00	0.00	[[V1]] on: means that there is sale data in the buffer. [[V2]] glittering: means that buffer 『V2』 is working
Execute sales. Users can switch to V3, V4 according to demands.					
Continue sale buffered in V1 for customer return.					
Switch buffer V1	【V1】	0.000	1.000	0.00	1.80	[[V1]] glittering.
Transfer PLU11	【1】【1】【PLU】			5.00	5.00	[[U.Price]], [[Single]] on.
Input PLU11 amount	【×】【5】		5	5.00	25.00	
Confirm a goods	【Confirm】	0.000	0.000	0.00	26.80	[[Sum]] on.
If payment is equal to total, don't input.		0.000	0.000	0.00	26.80	
Print	【Print】			0.00	26.80	[[Change]], [[Sum]] on. Execute print.
Finished sales buffered in V2~V4.						

4.6.2 Cancel Sale Data in Sale Buffers

Example 4-29 Clear All Data in Current Sale Buffers

Operations	Keys	Display				Remarks
		Tare	Weight/ Count	Change/ U.Price	Single/ Total	
『Sale Idle』		0.000	0.000	0.00	0.00	[[Sale]], [[Sum]] on.
Transfer PLU10	【1】【0】【PLU】	0.100	-0.100	2.00	0.00	[[U.Price]], [[Single]] on.
Put goods PLU10 on		0.100	0.900	2.00	1.80	
Confirm a goods	【Confirm】	0.000	1.000	0.00	1.80	[[Sum]] on.

Take goods PLU10 off		0.000	0.000	0.00	1.80	
Transfer PLU11	【1】【1】【PLU】			5.00	5.00	〔U.Price〕 , 〔Single〕 on.
Input PLU11 amount	【×】【5】		5	5.00	25.00	
Confirm a goods	【Confirm】	0.000	0.000	0.00	26.80	〔Sum〕 on.
Enter cancel interface	【Amend】	02.00	6		26.80	〔Sum〕 on.
		Total	Piece Number		Total Price	
Clear all data	【Confirm】	0.000	0.000	0.00	0.00	〔Sum〕 on.

Example 4-30 Clear One Goods in Current Sale Buffer

Operations	Keys	Display				Remarks
		Tare	Weight/Count	Change/U.Price	Single/Total	
〔Sale Idle〕		0.000	0.000	0.00	0.00	〔Sale〕 , 〔Sum〕 on.
Transfer PLU10	【1】【0】【PLU】	0.100	-0.100	2.00	0.00	〔U.Price〕 , 〔Single〕 on.
Put goods PLU10 on		0.100	0.900	2.00	1.80	
Confirm a goods	【Confirm】	0.000	1.000	0.00	1.80	〔Sum〕 on.
Take goods PLU10 off		0.000	0.000	0.00	1.80	
Transfer PLU11	【1】【1】【PLU】			5.00	5.00	〔U.Price〕 , 〔Single〕 on.
Input PLU11 amount	【×】【5】		5	5.00	25.00	
Confirm a goods	【Confirm】	0.000	0.000	0.00	26.80	〔Sum〕 on.
Enter amend interface	【Amend】	02.00	6		26.80	〔Sum〕 on.
		Total	Piece Number		Total Price	
Use 【←】【→】 to select goods	【→】	02.01	0.900	10	1.80	〔Single〕 on.
		Goods 1	Amount	PLU Number	Single Price	
Confirm amendment	【Confirm】	0.000	0.000	0.00	25.00	〔Sum〕 on.

Note 1 In amend window: the window of tare is in the form of xx xx. The first part shows accumulative times; the latter part is the object to be amended. 00 is total and 01~31 are accumulative number.

Note 2 If users amend the total, the whole deal is cleared.

Note 3 If users amend xx goods, information of xx goods is cleared. And if there was a T.Price discount, T.Price discount information is cleared. T.Price will be calculated based on U.Price (or discounted U.Price) and amount of sold goods.

Note 4 If T.Price is selected, the window of 〔Weight/Count〕 will display piece number of sold goods. The definition of piece number is: 5 count goods add 5 and each weight goods add 1.

4.7 Salesman and Waiter

4.7.1 Personnel Information

Please refer to *Salesman Programme* in page 55. Salesman and waiter use the same personnel sheet.

4.7.2 Salesman Function

Salesman Function is disabled as default. User can enable it at Spec135. Normally, Set Spec135=2 or 4.

Only non-zero password Personnel can login as salesman when Spec135=4 or 5.

User need to input salesman's number and password in the login menu before get into sale menu when

salesman function is enable.

4.7.3 Waiter Function

Do not enable in the common version, and do not have corresponding key.

4.8 Inquiry of Sale Records and Markers of Returns of Goods

Mark the tenth item in the sale record as return of goods.

Example 4-31 Inquiry of Sale Records and Markers of Returns of Goods

Operations	Keys	Display				Remarks
		Tare	Weight/ Count	Change/ U.Price	Single/ Total	
『Sale Idle』		0.000	0.000	0.00	0.00	[[Sale]], [[Sum]] on.
Enter 『Sale Records』	Long Press 【Amend】	2	5	11	25.00	If there is data in current buffer, system would first enter buffer interface, long press will enter current interface,. If there is no sale records, it will not enter this interface Information Page 1
		Note 2	Amount	PLU Number	Price	
Other information of record items	【↓】	2008	05 24	09 08	59 W-6	Sale time of records. Information Page 2
Other information of record items	【↓】	Note 5	Note 3	15 Note 4	15	Note 1 Information Page 3
Other information of record items	【↓】	02.02	5	11	25.00	
See previous record	【←】	02.01	0.900	10	1.80	
See record 10	【×】		Input	1 - 1	0	Switch to the appointed number record.
	【1】【0】 【Confirm】	01.01	1.000	12	4.00	
Other information of record items	【↓】	2008	05 24	08 01	39 W-6	
Other information of record items	【↓】			15	10	10 here is the appointed number.
Other information of record items	【↓】	01.01	1.000	12	4.00	
Sign as a return goods	【F-Prog】+ 【Amend】	01.01	1.000	12	4.00	
Return to sale mode	【Cancel】	0.000	0.000	0.00	0.00	[[Sale]], [[Sum]] on.

Note 1 The record are divided into deal head record and deal detailed record, deal head record include deal data of FID , SID, deal discount sum,etc; deal detailed record include the detailed cargo deal information

Note 2 When display deal head record, here display ‘----’, when display deal detailed record, here display this goods are which number cargo

Note 3 When display deal head record, here display this deal’s SID (code ID, refer to Spec140), when display deal detailed record, here is blank

Note 4 The number shown in the window of change / U.Price is the amount of sale record stored in the scale. When the number is close to 8000, the scale would delete the earliest records automatically. And Single/Total Price window shows the sequence number of this record in all the records

Note 5 If present record are marked as goods return, the window will display “-RT-” .

4.9 Manual Weight

4.9.1 Manual Sale of Manual Weight Entry

Example 4-32 Manual Sale of Manual Weight Entry

Sell 1 kg PLU10 goods. Assume PLU10 is a weight PLU with U.Price is \$2.00/kg and tare is 0.100kg.

Operations	Keys	Display				Remarks
		Tare	Weight/ Count	Change/ U.Price	Single/ Total	
[[Sale Idle]]		0.000	0.000	0.00	0.00	[[Sale]], [[Sum]] on.
Transfer PLU10	【1】【0】【PLU】	0.100	-0.100	2.00	0.00	[[U.Price]], [[Single]] on.
Manual weight entry	【Manual Weight】		Man	Weight	0.000	
Weight data	【1】【0】【00】		Man	Weight	1.000	
Put on a weight	【Confirm】	----	1.000	2.00	2.00	【Manual Weight】 on
Print	【Print】	0.000	0.000	0.00	0.00	Execute print.

Note 1 Manual weight entry need Spec077 set to non-zero (1, 2 or 3 are all ok).

Note 2 Manual weight entry can be executed only if weight keeps at zero and stable.

Note 3 In manual weight sale process, tare function is forbidden, [[Manual Weight]] on, and “ManWT” is printed before weight data.

4.10 Bar code printing and scanning

4.10.1 Exterior bar code

Exterior bar code is EAN/UPC barcode normally, which is defined by the standards organisation GS1.

If user look for commodity by exterior bar code, user need to input the commodity’s bar code to **PLU’s Index Barcode**, after the scanner scan the bar code, it will search and transfer the same index PLU automatically.

When user edit the PLU on the scale, scan the exterior bar code during the PLU number step, it will transfer the PLU related to the exterior bar code; if scans the exterior bar code in other step, it will consider this bar code as present PLU’s index barcode.

4.10.2 Interior bar code

Interior bar code is user appointed barcode format and only used in small area, generally used for communication between barcode scale and cash machine like cash register scale or cash register machine.

In the rule of EAN-UCC, define the prefix code 20-29 as shop inside use to avoid the repetition with EAN code. So, if user uses both exterior and interior bar code, then interior bar code’s prefix must inside 20-29.

To meet the different request, the interior bar code’s format can be defined by user, but the print device (barcode label scale) and scan device (cash register scale or cash register) must with the same format, then the interior barcode can be exactly recognised

5 Programme Operations

5.1 Please Read this Part First

For ordinary users, they can use 3 kinds of Fast Progs in *Fast Prog* in chapter 3 to handle most applications.

There are detailed programme operations of the scale in this chapter, as well as examples for users. But some parts of programme content are very complicated such as print format edit and barcode format edit. Devisers suggest users use company offered software when users are in need of these functions. The company software offers users a convenient interface to edit all the working parameters and sale data of the scale. The setting data can be downloaded from Ethernet (real-time download), or transferred in the form of files by USB flash disk (Users edit the data on PC and store data in USB flash disk, then download data to scale from USB flash disk.).

Devisers are convinced that it's easy to learn to use the company software. As long as users own basic computer operation knowledge and learn with user manual of this software (User manual would be installed with the software), users can operate the software in a very short time. If users cannot use computer and are still in need of complicated programme operations, users can write down the demands and send to us.

If computers cannot be used in users' circumstances, and users are indeed in need of functions of this part, please read content in this chapter carefully. In consideration of too much content, detailed example instructions of all operations will not be provided in some chapters. But all the functions are instructed in words and processes are arranged in sequence of steps. Users should read *Tree-shaped Design of Edit Steps* and *Frequently-used Keys in Prog Interfaces* first carefully. Then do programme operations according to instructions in *List of Programme Interface* and corresponding chapters on the basis of fully understanding of these two parts.

5.2 Basic Operations in Programme Interface

5.2.1 Tree-shaped Design of Edit Steps

Prog Menu	P1	Scale Paramete (TM-Set)	P11	Time	Press 【Prog】 first enter P1; Use 【←】 and 【→】 to select one of P1 to P5. Use 【Confirm】 to select corresponding programme operations; Or press 【1】 ~ 【5】 directly to enter P1 ~ P5; Then use the way to go to Next. The operations are a little different in various programme operations. But they are almost designed into tree-shaped. Instructions and examples about each part would be in following chapters. Note: Communication ways of P4 depend on the hardware of the scale. And basic
			P12	Spec	
			P13	Sring	
			P14	PLU Shortcut	
	P2	Sale Data (DT-Set)	P21	Dept.	
			P22	Class	
			P23	PLU	
			P24	Unit	
			P25	Barcode	
			P26	Print format	
			P27	Salesman	
	P3	Data Assistant (DT-Ass)	P31	PLU Prog steps	
			P32	PLU F-Prog steps	
			P33	Delete Sale data	
	P4	Communications (Commu)	P41	USB flash disk	
P42			Ethernet		

P5	Hardware Assistant (HWAss)	P43	RS232	hardware only has P41.
		P44	USB slave	
		P51	Set the passwords	
		P52	Factory default	

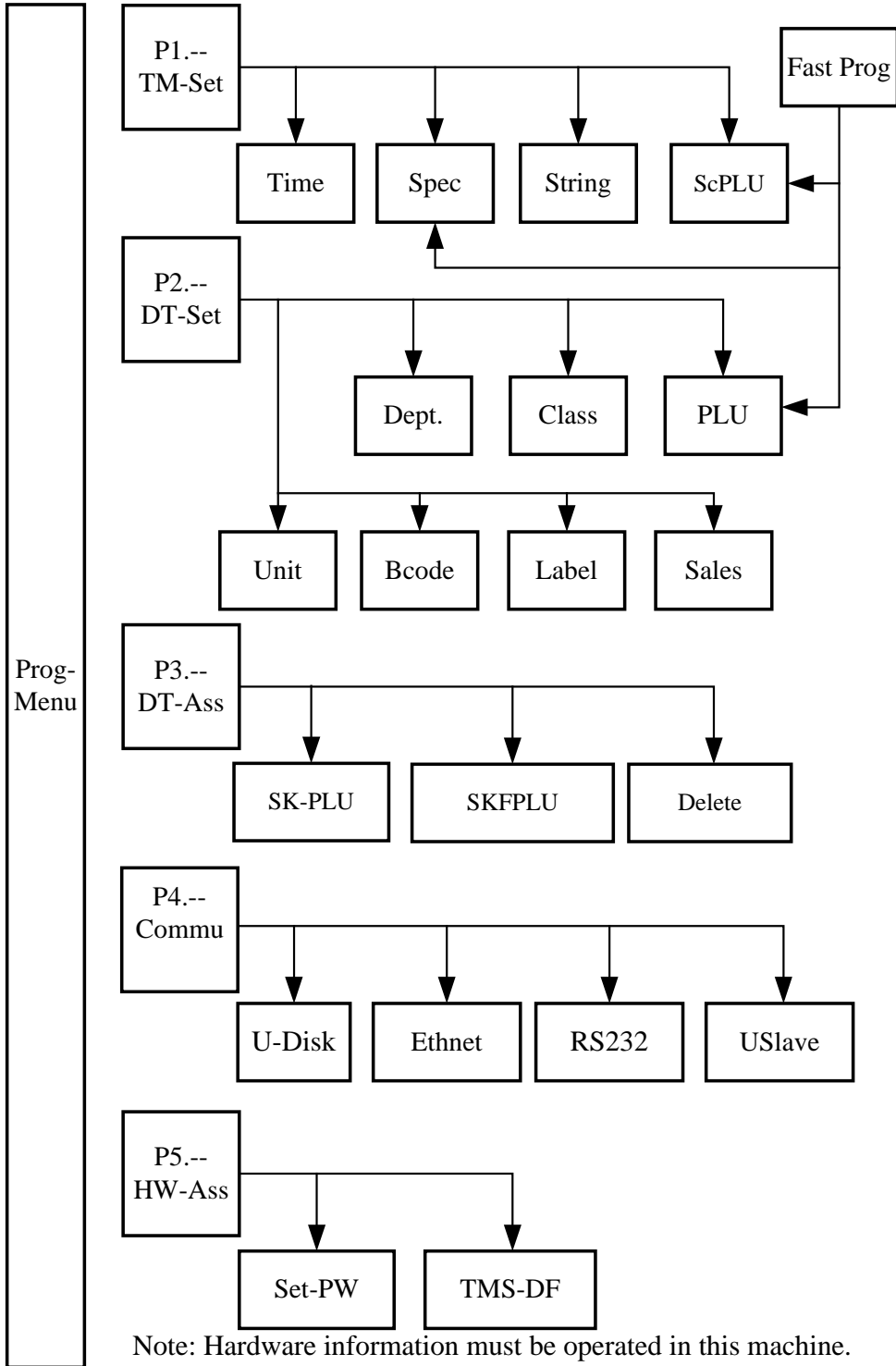

Picture 5-1 Sketch map of tree-shaped design of edit interface

5.2.2 Frequently-used Keys in Prog Interfaces

- **【Amend】**: Save the amended content and go back to previous interface. If operation is in DTSet, go

back to step 0 after save and wait for new number to be input to amend.

- **【Cancel】** : Don't save and go back to previous interface.
- **【Confirm】** : Get into next step to edit. Such as enter P3 by pressing **【Confirm】** when operation is in P31. And press **【Confirm】** to enter certain edit interface when operation is in text edit or in edit interface of print format. Then press **【Amend】** to save and exit, or press **【Cancel】** to exit without saving.
- **【←】、【→】** : Steps selection. Such as press **【←】** and **【→】** to select steps P21~ P27
- **【↑】、【↓】** : Press **【↑】** **【↓】** to select previous or next valid data when amending data in programme. And its function is the same as **【←】** **【→】** in some interfaces when no data is to be amended.
- **【0】 ~ 【9】、00**: Input corresponding numbers.
- **【back】** : Delete the last digit number.
- **【×】** : For so many steps to select in processes of Spec and DTSet edit operations in TMSet, users can use **【×】** to select step to edit. There would be a hint for you to input the step number you want to select after you press **【×】** . Please input the number and press **【Confirm】** .

5.2.3 List of Programme Interface

Menus	Menu Prompt	Instructions	Remarks	State
P1	TMSet	BarCode Scale Setting		
P11	TMSet Time			
P12	TMSet Spec	Spec Parameters setting		
P12	SP.000	Spec 000	Spec 000~249, see details in chapter 7.2 <i>Definitions of Spec data parameters</i>	
.....		
P12	SP.249	Spec 249		
P13	TMSet String	Text setting		
P13	ST.000 ShopN	String 0: Store name		
P13	ST.001 ScaleN	String 1: Device name		
P13	ST.002 MnyPre	String 2: Prefix of Money Unit		
P13	ST.003 MnySuf	String 3: Suffix of Money Unit		
P14	TMSet scPLU	PLU shortcut key setting		
P2	DTSet	Scale Data setting		
P21	DTSet Dept	Dept. setting		
P21	DPT.00 NoSet	Dept.0: Number	Available dept edit number: 10~99.	
P21	DPT.01 Name	Dept.1: Name		
P22	DTSet Class	Class		
P22	CLS.00 NoSet	Class 0: Number	Available class edit number 10~99	
P22	CLS.01 Name	Class 1: Name		
P22	CLS.00 Dept	Class 2: Dept. that it belong to		
P23	DTSet PLU	PLU		
P23	PLU.00 NoSet	PLU 0: Number	Available PLU edit number 1~9999999.	
P23	PLU.01 ICode	PLU 1: Item Code	Be printed with barcodes.	
P23	PLU.02 Index	PLU 2: Index for exterior barcode		

Menus	Menu Prompt	Instructions	Remarks	State
P23	PLU.03 Unit	PLU 3: Unit	1 is default weight unit; 2 is default weight unit; 3 is kg weight unit; 4 is g weight unit; 5 is ton weight unit; 6 is pound weight unit; 7 is 500g weight unit; 8 is 100g weight unit.	
P23	PLU.04 Price	PLU 4: U.Price		
P23	PLU.05 Cost	PLU 5: Cost		
P23	PLU.06 Tare	PLU 6: Tare		
P23	PLU.07 Lab-1	PLU 7: Print format number of 1 st bill		
P23	PLU.08 BarT1	PLU 8: Barcode number of 1 st bill		
P23	PLU.09 BarF1	PLU 9: Barcode flag of bill 1 st bill		
P23	PLU.10 Lab-2	PLU 10: Print format number of 2 nd bill		
P23	PLU.11 BarT2	PLU 11: Barcode number of 2 nd bill		
P23	PLU.12 BarF2	PLU 12: Barcode flag of 2 nd bill		
P23	PLU.13 Class	PLU 13: class that it belongs to		
P23	PLU.14 Name	PLU 14: Goods name		
P23	PLU.15 Des-1	PLU 15: Goods postil 1		
P23	PLU.16 Des-2	PLU 16: Goods postil2		
P23	PLU.17 Des-3	PLU 17: Goods postil3		
P23	PLU.18 Des-4	PLU 18: Goods postil4		
P23	PLU.19 Des-5	PLU 19: Goods postil5		
P23	PLU.20 Des-6	PLU 20: Goods postil6		
P23	PLU.21 Des-7	PLU 21: Goods postil7		
P23	PLU.22 PS-SD	PLU 22: Sale date print	0: not print, 1: print.	
P23	PLU.23 PS-ST	PLU 23: Sale time print	0: not print, 1: print at appointed time, 2: print printing time.	
P23	PLU.24 PS-PD	PLU 24: Packing date print	0: not print, 1: print.	
P23	PLU.25 PS-PT	PLU 25: Packing time print	0: not print, 1: print at appointed time, 2: print printing time.	
P23	PLU.26 PS-UD	PLU 26: Shelf date print	0: not print, 1: print.	
P23	PLU.27 PC-SD	PLU 27: Sale days data	Number of days after current day.	
P23	PLU.28 PC-ST	PLU 28: Sale time data	Appointed time for print.	
P23	PLU.29 PC-PD	PLU 29: Packing days data	Number of days after current day.	
P23	PLU.30 PC-PT	PLU 30: Packing time data	Appointed time for print.	
P23	PLU.31 PC-UD	PLU 31: Shelf days data	Number of days after current day.	
P23	PLU.32 DF-D	PLU 32: Manual discount lower limit	0: use system setting; 1: no lower limit; 2: Take original cost as lower limit; 3: Take PLU.34 as lower limit.	
P23	PLU.33 DF-U	PLU 33: Manual discount upper limit	0: use system setting; 1: no upper limit; 2: Take original U.Price as upper limit; 3: Take PLU.35 as upper limit.	
P23	PLU.34 DF-DN	PLU 34: Value of manual discount lower limit	Activated when DF_D=3.	
P23	PLU.35 DF-UN	PLU 35: Value of manual discount upper limit	Activated when DF_D=3.	

Menus	Menu Prompt	Instructions	Remarks	State
P23	PLU.36 DA-S0	PLU 36: Customize 0 of auto discount	0: not activate; 1: discount on count; 2: discount on periods of time.	
P23	PLU.37 DA-W0	PLU 37: Activation day of the customize	Sunday: 1, Monday: 2, Tuesday: 4 Wednesday: 8, Thursday: 16, Friday: 32 Saturday: 64. When this customization discount needs to be activated at some certain days, input add-up number of these days here. To input 127 means that the discount is activated all the days. To input $1 + 64 = 65$ if the discount is only activated at Saturday or Sunday.	
P23	PLU.38 DA-D0	PLU 38: The Lower limit of customization activation period Start at this point (include this point)	Execute this discount way in this customization activation period. Input weight/count according to the unit of PLU when discount on amount. When inputting count, 10 goods needs to input 10.000 or move decimal (long press 【Shift】 or 【F-Prog】 + 【Shift】) to input 10. Avoid inputting 0.010 for 10 pcs.	
P23	PLU.39 DA-U0	PLU 39: The upper limit of customization activation period End at this point (not include this point)	When discount on time, the format of input time is HHMM. If the time is 20: 30, users need to move decimal to input 2030.	
P23	PLU.40 DA-N0	PLU 40: Discount Price of customize	If number is positive, discount number would replace U.Price. If number is minus, new U.Price is the price that subtracts the input number from former U.Price. But minus values cannot be input in the scale.	
P23	PLU.41 DA-S1	PLU 41: Customize 1 of auto discount	It's the same as last customize discount. After the edit of last customize discount it can be edited.	
P23	PLU.42 DA-W1	PLU 42: Activation day of the customize		
P23	PLU.43 DA-D1	PLU 43: The Lower limit of customization activation period		
P23	PLU.44 DA-U1	PLU 44: The upper limit of customization activation period		
P23	PLU.45 DA-N1	PLU 45: Discount Price of customize		
P23	PLU.46 DA-S2	PLU 46: Customize 2 of auto discount	It's the same as last customize discount. After the edit of last customize discount it can be edited.	
P23	PLU.47 DA-W2	PLU 47: Activation day of the customize		
P23	PLU.48 DA-D2	PLU 48: The Lower limit of customization activation period		
P23	PLU.49 DA-U2	PLU 49: The upper limit of customization activation period		
P23	PLU.50 DA-N2	PLU 50: Discount Price of customize		
P23	PLU.51 DA-S3	PLU 51: Customize 3 of auto discount	It's the same as last customize discount. After the edit of last customize discount it can be edited.	
P23	PLU.52 DA-W3	PLU 52: Activation day of the customize		
P23	PLU.53 DA-D3	PLU 53: The Lower limit of customization activation period		
P23	PLU.54 DA-U3	PLU 54: The upper limit of customization activation period		
P23	PLU.55 DA-N3	PLU 55: Discount Price of customize		

Menus	Menu Prompt	Instructions	Remarks	State
P23	PLU56 Tax-S	PLU56: tax rate sort	0: excute tax rate according to Spec 116,117 1: tax free price mode 2:: tax free price mode, input unit price is price duty paid 3.with tax price mode	
P23	PLU.57 Tax-D	PLU57: tax rate percentage	0.01% tax rate,17% input 1700	
P24	DTSet Unit	Unit		
P24	UNT.00 NoSet	Unit 0: Number		
P24	UNT.01 Name	Unit 1: Name		
P24	UNT.04 PUnit	Unit 4: Measure Mode(just open weighing mode)	1 is default weight unit, 2 is default count unit,	Not Open
P24	UNT.05 Pack	Unit 5: Packing	In weighing mode, means how much gram as one packing In counting mode, means how many pcs as one packing	Not Open
P25	DTSet Bcode	Barcode		
P25	BAR.00 NoSet	Barcode 0: Number	Edited number of barcode when leaving factory are 1~9. Available barcode edit number 10~99.	
P25	BAR.01 Name	Barcode 1: Name		
P25	BAR.02 Type	Barcode 2: Type		
P25	BAR.03 Check	Barcode 3: Checkout		
P25	BAR.04 NCon1	Barcode 4: Constant number 1		
P25	BAR.05 NCon2	Barcode 5: Constant number 2		
P25	BAR.05 Des	Barcode 6: Data format description	Please pay attention that edit content should accord with certain format: refer to chapter of barcode.	
P26	DTSet PSets	Print format		
P26	PST.00 NoSet	Print format 0: Number	Edited label in factory: 1~9; Available label edit number 10~29.	
P26	PST.01 Name	Print format 1: Name		
P26	PST.02 Sort	Print format 2: Using sort		
P26	PST.03 Lng-X	Print format 3: Width		
P26	PST.04 Lng-Y	Print format 4: Height		
P26	PST.05 Txt01	Print format 5: Text 1		
P26	PST.06 Txt02	Print format 6: Text 2		
P26	PST.07 Txt03	Print format 7: Text 3		
P26	PST.08 Txt04	Print format 8: Text 4		
P26	PST.09 Txt05	Print format 9: Text 5		
P26	PST.10 Txt06	Print format 10: Text 6		
P26	PST.11 Txt07	Print format 11: Text 7		
P26	PST.12 Txt08	Print format 12: Text 8		
P26	PST.13 Txt09	Print format 13: Text 9		
P26	PST.14 Txt10	Print format 14: Text 10		
P26	PST.15 Txt11	Print format 15: Text 11		
P26	PST.16 Txt12	Print format 16: Text 12		
P26	PST.17 Txt13	Print format 17: Text 13		
P26	PST.18 Txt14	Print format 18: Text 14		

Menus	Menu Prompt	Instructions	Remarks	State
P26	PST.19 Txt15	Print format 19: Text 15		
P26	PST.20 Txt16	Print format 20: Text 16		
P26	PST.21 FontM	Print format 21: Font mode	Suggest new font mode after V2.03 but still support old font	
P26	PST.22 LAS	Print format 22: Print Item		
P26	LAS.00 NoSet	Print item 0: Item number	Available print item edit number 0~99.	
P26	LAS.01 Flag1	Print item 1: Symbol 1		
P26	LAS.02 Flag2	Print item 2: Symbol 2		
P26	LAS.03 Flag3	Print item 3: Symbol 3		
P26	LAS.04 Print	Print item 4: Print state		
P26	LAS.05 Angel	Print item 5: Print angle		
P26	LAS.06 Grid	Print item 6: Type of snap to grid		
P26	LAS.07 CFont	Print item 7: Print font		
P26	LAS.08 S-X	Print item 8: Start position X		
P26	LAS.09 S-Y	Print item 9: Start position Y		
P26	LAS.10 L-X	Print item 10: Area length X		
P26	LAS.11 L-Y	Print item 11: Area length Y		
P27	DTSets Sales	Salesman	Available salesman edit number 10~99	
P27	SAL.00 NoSet	Salesman 0: Number		
P27	SAL.01 Name	Salesman 1: Salesman name		
P27	SAL.02 Pass	Salesman 1: Salesman password		
P3	DTAss	Data assistant		
P31	DTAss Sk-PLU	PLU Prog skip step setting		
P31	PLU.00 NoSet	PLU 0: Number	Choice 0: Prog means to be programme, Choice 1: Skip means skiped in programme	
P31	PLU.01 ICode	PLU 1: Item Code		
P31	PLU.02 Index	PLU 2: Index for exterior barcode		
P31	PLU.03 Unit	PLU 3: Unit		
P31	PLU.04 Price	PLU 4: U.Price		
P31	PLU.05 Cost	PLU 5: Cost		
P31	PLU.06 Tare	PLU 6: Tare		
P31	PLU.07 PST-1	PLU 7: Print format number of 1 st bill		
P31	PLU.08 BarT1	PLU 8: Barcode number of 1 st bill		
P31	PLU.09 BarF1	PLU 9: Barcode flag of bill 1 st bill		
P31	PLU.10 PST-2	PLU 10: Print format number of 2 nd bill		
P31	PLU.11 BarT2	PLU 11: Barcode number of 2 nd bill		
P31	PLU.12 BarF2	PLU 12: Barcode flag of 2 nd bill		
P31	PLU.13 Class	PLU 13: class that it belongs to		
P31	PLU.14 Name	PLU 14: Goods name		
P31	PLU.15 Des-1	PLU 15: Goods postil 1		
P31	PLU.16 Des-2	PLU 16: Goods postil2		
P31	PLU.17 Des-3	PLU 17: Goods postil3		
P31	PLU.18 Des-4	PLU 18: Goods postil4		
P31	PLU.19 Des-5	PLU 19: Goods postil5		
P31	PLU.20 Des-6	PLU 20: Goods postil6		
P31	PLU.21 Des-7	PLU 21: Goods postil7		
P31	PLU.22 PS-SD	PLU 22: Sale date print Attached: PLU.27: Sale date data		

Menus	Menu Prompt	Instructions	Remarks	State
P31	PLU.23 PS-ST	PLU 23: Sale time print Attached: PLU.28: Sale time data		
P31	PLU.24 PS-PD	PLU 24: Packing date print Attached: PLU.29: Packing date print		
P31	PLU.25 PS-PT	PLU 25: Packing time print Attached: PLU.30: Packing time data		
P31	PLU.26 PS-UD	PLU 26: Shelf date print Attached: PLU.31: Shelf date data		
P31	PLU.32 DF-U	PLU 32: Manual discount upperlimit Attached: PLU.34		
P31	PLU.33 DF-D	PLU 33: Manual discount lower limit Attached: PLU.35		
P31	PLU.36 DA-S0	PLU 36: Customize 0 of auto discount Attached: PLU.37-PLU.55		
P32	DTAss SkFPLU	PLU F-Prog skip step setting		
The same as P31				
P33	DTAss Delete	Delete data of the scale	Validate code is needed to enter: 9958.	
P33	DEL.01 Dept	Delete1: Dept.	When entering to delete, system would request to input 2 numbers which mean the start number and the end number of the data to delete. If the end number is 0, only data of the start number would be deleted. If the number is not 0 and it's less than start number, no data would be deleted.	
P33	DEL.02 Class	Delete2: Class		
P33	DEL.03 PLU	Delete3: PLU		
P33	DEL.04 Unit	Delete4: Unit		
P33	DEL.05 BCode	Delete5: Barcode		
P33	DEL.06 PSets	Delete6: Print format		
P33	DEL.07 Sales	Delete7: Salesman		
P4	Commu	Communication setting		
P41	Commu U-Disk	Load and save of data in USB flash disk		
P42	Commu Ethnet	Not real-time Download from Ethernet		
P43	Commu RS-232	RS232communication		
P44	Commu USlave	USB slave communication		Not Open
P44	Commu PTR	Ethernet printer communication		
P5	HWAss	Hardware assistant setting	Admin password is required to enter administrator's password: 200806	
P51	HWAss Set-PW	Hardware: setting password		
P511	HWAss Set-PW	Admin : Admin password	Input same passwords 2 times to complete amendment of password.	
P512	HWAss Set-PW	Sale : Sale password		
P513	HWAss Set-PW	Prog : Prog password		
P514	HWAss Set-PW	Account : Account password		
P515	HWAss Set-PW	Drawer : Drawer password		
P52	HWAss TMS-DF	Hardware: Recover factory default		
P521	HWAss TMS-DF	Fac-Set : Scale parameter(P1x)	The interface that requires to input validate code would be shown before default setting. Input 9958 to finish setting.	
P522	HWAss TMS-DF	Base-DT : Default working data(P2x default)		
P523	HWAss TMS-DF	EraseDT : All working data(P2x)		
P524	HWAss TMS-DF	Fac-All : All parameters and data(P2x)		

5.3 The Edit of All Parts in TMSet

5.3.1 Time Programme

Example 5-1 Time Programme

Operations	Keys	Display				Remarks
		Tare	Weight/ Count	Change/ U.Price	Single/ Total	
〔Sale Idle〕		0.000	0.000	0.00	0.00	〔Sale〕 , 〔Sum〕 on.
Enter programme	【Prog】	P1	TMSet			〔Prog〕 on.
Enter TMSet	【1】	P11	TMSet	Time		
Enter time programme	【1】	2008	05 19	20 21	51 W-1	W-0 means Sunday, W-1 means Monday, and the like.
		Year	Month Day	Hour Minute	Second Week	
Input current time by number key					Cursor indicates current editing object. And using 【←】【→】 could move the position of cursor.
Save time	【Amend】	P11	TMSet	Time		Save to the scale.
Return to sale	【Sale】	0.000	0.000	0.00	0.00	〔Sale〕 , 〔Sum〕 on.

5.3.2 Programme of Spec Parameters

Example 5-2 Programme of Spec parameters

Operations	Keys	Display				Remarks
		Tare	Weight/ Count	Change/ U.Price	Single/ Total	
〔Sale Idle〕		0.000	0.000	0.00	0.00	〔Sale〕 , 〔Sum〕 on.
Enter programme	【Prog】	P1	TMSet			〔Prog〕 on.
Enter TMSet	【1】	P11	TMSet	Time		
Enter Spec	【2】	P12	SP.000	1	1	
			Spec No.	Origin Set	Current Set	
Change to 2	【2】	P12	SP.000	1	2	
Enter Spec002	【→】【→】	P12	SP.002	0	0	Using 【←】【→】 can only get to amend items in Spec amend level 0.
Change to 77	【7】【7】	P12	SP.002	0	77	
Choose steps directly	【×】		Input	1 - 1	0	
Input step 40	【4】【0】		Input	1 - 1	40	The input number of step must be in Spec amend level 0 or 1. If not, the step cannot be reached.
Confirm step	【Confirm】	P12	SP.040	0	0	
Change to 99	【9】【9】	P12	SP.040	0	99	
Save and exit	【Amend】	P12	TMSet	Spec		
Return to sale	【Sale】	0.000	0.000	0.00	0.00	〔Sale〕 , 〔Sum〕 on.

Note 1 The way it programmes is the same as the way in *Fast-Prog of Spec Parameters* in page 19, except the way it enters programme page.

Note 2 Please refer to *Definitions of Spec data parameters* in page 73 for definitions of all items of Spec

data parameters.

5.3.3 Programme of Text Parameters

Example 5-3 Programme of Text Parameters

Operations	Keys	Display				Remarks
		Tare	Weight/ Count	Change/ U.Price	Single/ Total	
『Sale Idle』		0.000	0.000	0.00	0.00	[[Sale]], [[Sum]] on.
Enter programme	【Prog】	P1	TMSet			[[Prog]] on.
Enter TMSet	【1】	P11	TMSet	Time		
Enter String	【3】	P13	ST.000	ShopN	Push-OK	ST.000 is store name.
			String No.	String Info		
Switch to device name	【→】	P13	ST.001	ScaleN	Push-OK	ST.001 is device name.
Switch to store name	【←】	P13	ST.000	ShopN	Push-OK	
Enter editing	【Confirm】	EN-1	0			
Clear original text	【End】	EN-1	0			In view of have original text, Suggesting users press 【End】 before editing to clear former text.. If modify on original literal, use 【←】 【→】 to move cursor to target position
Switch to EN-2	【Switch】	EN-2	0		0	
Save editing text	【Amend】	P13	PLU.14	Name	OK-Edit	Save to the scale.
Return to sale mode	【Sale】	0.000	0.000	0.00	0.00	[[Sale]], [[Sum]] on.

Note 1 Please refer to 7.3 *Definitions of String data parameters* for definitions of each text parameter.

5.3.4 Programme of PLU Shortcut Keys

Example 5-4 Programme of PLU Shortcut Keys

Operations	Keys	Display				Remarks
		Tare	Weight/ Count	Change/ U.Price	Single/ Total	
『Sale Idle』		0.000	0.000	0.00	0.00	[[Sale]], [[Sum]] on.
Enter programme	【Prog】	P1	TMSet			[[Prog]] on.
Enter TMSet	【1】	P11	TMSet	Time		
Enter PLU shortcut key	【4】	P14	scPLU	-----	-----	
Set SC1	【SC1】	P14	scPLU	0-01	0	
Input PLU number	【1】【0】	P14	scPLU	0-01	10	
Confirm input	【Confirm】	P14	scPLU	-----	-----	Save to temporary buffer.
Set SC2	【SC2】	P14	scPLU	0-02	0	
Input PLU number	【1】【1】	P14	scPLU	0-02	11	
Confirm input	【Confirm】	P14	scPLU	-----	-----	Save to temporary buffer.
Set Shift+SC1	【Shift】【SC1】	P14	scPLU	1-01	0	
Input PLU number	【1】【0】【0】	P14	scPLU	1-01	100	

Confirm input	【Confirm】	P14	scPLU	-----	-----	Save to temporary buffer. The last confirm can be skipped. Press 【Amend】 directly.
Save editing text	【Amend】	P14	TMSet	scPLU		Save to the scale.
Return to sale mode	【Sale】	0.000	0.000	0.00	0.00	[[Sale]], [[Sum]] on.

Note 1 The way it programmes is the same as the way of Example 3-2 and Example 3-3 in page 18, except the way it enters programme interface.

5.3.5 Programme of Fuction Shortcut Keys

Example 5-5 Programme of Fuction Shortcut Keys

Operations	Keys	Display				Remarks
		Tare	Weight/ Count	Change/ U.Price	Single/ Total	
[[Sale Idle]]		0.000	0.000	0.00	0.00	[[Sale]], [[Sum]] on.
Enter programme	【Prog】	P1	TMSet			[[Prog]] on.
Enter TMSet	【1】	P11	TMSet	Time		
Enter Fuction shortcut	【5】	P15	scFuc	-----	-----	
Set SC1	【SC1】	P15	scFuc	0-01	0	
Input Fuction number	【7】【6】	P15	scFuc	1	76	Fuction “Custom Info 1”=76
Save editing text	【Amend】	P15	TMSet	scFuc		Save to the scale.
Return to sale mode	【Sale】	0.000	0.000	0.00	0.00	[[Sale]], [[Sum]] on.

Note 1 Please refer to 7.4 *Definitions of Shortcut Function Key* for details

5.4 The Edit of All Parts in DTSet

5.4.1 Department Programme

The department (Dept. for short) is the largest category in sales statistics. And it’s marked with number from 1 to 99 and the corresponding meanings are shown below:

Number	Use	Instructions
1	System Dept.	Not edited weight Dept.
2	System Dept.	Not edited count Dept.
8	System Dept.	Error Dept.
9	Default Dept.	Default Dept. for Class editing
10~99	User Dept.	Dept. that users can edit

Example 5-6 Department Programme

Operations	Keys	Display				Remarks
		Tare	Weight/ Count	Change/ U.Price	Single/ Total	
[[Sale Idle]]		0.000	0.000	0.00	0.00	[[Sale]], [[Sum]] on.
Enter programme	【Prog】	P1	TMSet			[[Prog]] on.
Enter DTSet	【2】	P21	DTSet	Dept		
Enter Dept. programme	【1】	P21	DPT.00	NoSet	0	
			Step No.	Step Info	Object	
Enter number 10	【1】【0】	P21	DPT.00	NoSet	10	
Next	【→】	P21	DPT.01	Name	OK-Edit	

Edit department name						Department names would usually not be printed. And they are always used for management in PC. So editing their names is of little meaning. Here we skip it off.
Save editing data	【Amend】	P21	DPT.00	NoSet	0	Continue to edit other
Return to sale mode	【Sale】	0.000	0.000	0.00	0.00	[[Sale]], [[Sum]] on.

5.4.2 Class Programme

Class is the second largest category in sales statistics. And it is marked with number from 1 to 99 and the corresponding meanings are shown below:

Number	Dept.	Use	Instructions
1	1	System Class	Not edited weight Class
2	2	System Class	Not edited count Class
8	8	System Class	Error Class
9	9	Default Class	Default Class for PLU editing
10~99		User Class	Class that users can edit

Example 5-7 Class Programme

Operations	Keys	Display				Remarks
		Tare	Weight/ Count	Change/ U.Price	Single/ Total	
[[Sale Idle]]		0.000	0.000	0.00	0.00	[[Sale]], [[Sum]] on.
Enter programme	【Prog】	P1	TMSets			[[Prog]] on.
Enter DTSet	【2】	P21	DTSets	Dept		
Enter class programme	【2】	P22	CLS.00	NoSet	0	
			Step No.	Step Info	Object	
Input class number 10	【1】【0】	P22	CLS.00	NoSet	10	
Next	【→】	P22	CLS.01	Name	OK-Edit	
Edit class name						Class names would usually not be printed. And they are always used for management in PC. So editing their names is of little meaning. Here we skip it off.
Next	【→】	P22	CLS.02	Dept	0	Department that the class belongs to. And the department must exist.
Input department number 10	【1】【0】	P22	CLS.02	Dept	10	
Save editing class	【Amend】	P22	CLS.00	NoSet	0	Continue to edit other classes.
Return to sale mode	【Sale】	0.000	0.000	0.00	0.00	[[Sale]], [[Sum]] on.

5.4.3 PLU Programme

Price-LookUp is information cell for goods sale. Serial number of PLU, as the only sign of scale store PLU, is defined by user to correspond to actual goods. Remark number, as the number defined by users or the serial number of actual goods, is often printed as barcode. All the serial numbers which can be edited by users are from

10 to 9999999. And special serial numbers are corresponding to the meanings shown below:

Internal Number	Number	Class	Use	Instructions
1	9999999	1	System PLU	Not edited weight PLU
2	9999998	2	System PLU	Not edited count PLU
3	9999997	3	System PLU	Service charge PLU
10~5999	1~9999996		User PLU	PLU for users to edit

Example 5-8 PLU Programme

Operations	Keys	Display				Remarks
		Tare	Weight/Count	Change/U.Price	Single/Total	
〔Sale Idle〕		0.000	0.000	0.00	0.00	〔Sale〕, 〔Sum〕 on.
Enter Prog	【Prog】	P1	TMSet			〔Prog〕 on.
Enter DTSet	【2】	P21	DTSet	Dept		
PLU Prog	【3】	P23	PLU.00	Not Set	0	〔Prog〕 on.
			Step No.	Step Info	Object	
PLU Number	【1】【0】	P23	PLU.00	Not Set	10	Number are between 1~9999999
Go to Next	【→】	P23	PLU.01	ICode	0	
Input Item-Code	90001	P23	PLU.01	ICode	90001	ICode is Item-Code, which is usually printed as part of letters on barcode print. If the number of barcodes is default 2/5 or other custom numbers, ICode are printed as a part of barcodes. Please see details in chapter Barcode.
Go to Next	【→】	P23	PLU.03	Unit	0	
Set as weight PLU	【1】	P23	PLU.03	Unit	1	【0】 , 【1】 : default weight unit; 【2】 : default count unit; 【3】 : kg weight unit; 【4】 : g weight unit; 【5】 : ton weight unit; 【6】 : lb weight unit; 【7】 : 500g weight unit; 【8】 : 100g weight unit; Please see details in unit chapter. Default weight unit mean the unit used for display. And it is suggested for weight PLU.
Go to Next	【→】	P23	PLU.04	Price	0.00	
Set U.Price	【3】【0】【00】	P23	PLU.04	Price	30.00	Preset U.Price in sale. Don't have to input it. Users can temporarily input it in sale.
Go to Next	【→】	P23	PLU.05	Cost	0.00	
Set cost	【2】【4】【00】	P23	PLU.05	Cost	24.00	The cost is used to calculate the profits. Don't have to input it.
Go to Next	【→】	P23	PLU.06	Tare	0.000	

Set Tare	【5】	P23	PLU.06	Tare	0.005	When transferring PLU, it's preset tare. Don't have to input it.
Go to Next	【→】	P23	PLU.14	Name	OK-Edit	Input the names of goods.
Set name	【Confirm】	En-1	0			
Clear Original Text	【End】	EN-1	0			In consideration of there was a text, we suggest users press 【End】 before editing. If editing in the original text, users could use 【←】 【→】 to move the position of cursor.
P	【Shift】 【p/P】	EN-1	1	P		
o r k	【o/O】 【r/R】 【k/K】	EN-1	4	rk		
-	【-】	EN-1	5	k-		
Input number 2	【2】	En-1	6	-2		
Save edited text	【Amend】	P23	PLU.14	Name	OK-Edit	This 【Amend】 is to save text edit in buffers instead of PLU. Please pay attention: If users need save it in PLU, users need to press 【Amend】 again as the step below.
Go to next	【→】	P23	PLU.26	PS-UD	0	If to print the shelf life date 0: Don't print PLU 31 invalid 1: Print. Continiune to set shelf days in PLU.31
Print shelf date	【1】	P23	PLU.26	PS-UD	1	
Go to next	【→】	P23	PLU.31	PC-UD	0	Shelf days. 0 means intraday valid, followed like this. If all cargo for one scale use same shelf days, use Spec105 & Spec106
Input shelf days	【→】	P23	PLU.31	PC-UD	3	
.....		P23				If other steps are still to be edited, users can use 【←】 【→】 to switch steps.
Save edited PLU	【Amend】	P23	PLU.00	Not Set	0	PLU10 is saved.
Return to sale	【Sale】	0.000	0.000	0.00	0.00	【Sale】 , 【Sum】 on

Note 1 Except the parts which have been instructed, meaning of the other words are listed *List of Programme Interface* in page 46

Note 2 The way it programmes is the same as the way Fast-Prog of Example 3-1 in page 16, except the way it enters programme page.

Note 3 xx is not continuous when users press 【←】 and 【→】 to select the programme content. There are two reasons. First reason is that the content in this part is meaningless. For example, tare is not present in count PLU programme. The second reason is that the content in that part is seldom used and has been set as non-programme content (Skip) in P31 and P32. Users could change that setting for personel usage and please refer to corresponding chapters for details.

5.4.4 Unit Programme

Unit is the basis of sale price. The scale has shielded parts of functions in consideration that edit of units may

cause unnecessary trouble. The 8 units edited when when the scale is released from factory are shown as below:

Number	Instructions
1	Default weight unit
2	Default count unit
3	Kg unit
4	g unit
5	ton unit
6	lb unit
7	500g unit
8	100g unit
9~19	System reserved unit
20~99	Unit for user to add

Note 1 Default weight unit is the measure unit of the scale.

Example 5-9 Unit Programme

Operations	Keys	Display				Remarks
		Tare	Weight/ Count	Change/ U.Price	Single/ Total	
〔Sale Idle〕		0.000	0.000	0.00	0.00	〔Sale〕 , 〔Sum〕 on.
Enter programme	【Prog】	P1	TMSet			〔Prog〕 on.
Enter DTSet	【2】	P21	DTSet	Dept		
Enter unit programme	【4】	P24	UNT.00	NoSet	0	
			Step No.	Step Info	Object	
Enter number 30	【3】【0】	P24	UNT.00	NoSet	30	
Next	【→】	P24	UNT.01	Name	OK-Edit	
Set unit name	【Confirm】	En-1	0			Unit name printed as unitage
Clear original text	【End】	En-1	0			
Save editing text	【Amend】	P24	UNT.01	Name	OK-Edit	Save unit to buffer
Save editing unit	【Amend】	P24	UNT.00	NoSet	0	Go on edit other unit
Return to sale mode	【Slae】	0.000	0.000	0.00	0.00	〔Sale〕 , 〔Sum〕 on.

5.4.5 Barcode Programme

Barcodes have different meanings in various applications and coding systems. Some barcodes are already edited when the scale is released from factory. Users could choose some barcodes from them to use or edit the barcode for themselves.

Number	Use	Instructions
1~9	Factory Default	Already edited when the scale is released from factory User cannot edit them.
10~99	User's barcode	Barcode that can be edited by users

Example 5-10 Barcode Programme

Operations	Keys	Display				Remarks
		Tare	Weight/ Count	Change/ U.Price	Single/ Total	
〔Sale Idle〕		0.000	0.000	0.00	0.00	〔Sale〕 , 〔Sum〕 on.
Enter programme	【Prog】	P1	TMSet			〔Prog〕 on.

Enter DTSet	【2】	P21	DTSet	Dept		
Enter barcode	【5】	P25	BAR.00	NoSet	0	
			Step No.	Step Info	Object	
Enter number 10	【1】【0】	P25	BAR.00	NoSet	10	
Next	【→】	P25	BAR.01	Name	OK-Edit	
Edit barcode names						Barcode names would usually not be printed. And they are always used for management in PC. So editing their names is of little meaning. Here we skip it off.
Next	【→】	P25	BAR.02	Type	0	See Table 5-1 <i>List of Barcode Types</i> .
Next	【→】	P25	BAR.03	Check	0	See Table 5-2 <i>Check Digit of Barcode</i> .
Next	【→】	P25	BAR.04	NCon1	0	It could be used as fixed number in barcode data.
Next	【→】	P25	BAR.05	Ncon2	0	
Next	【→】	P25	BAR.06	Des	OK-Edit	
Edit the descriptions of barcodes		P25				Barcode descriptions should be in exact appointed format and edit a text with the length of 24. Otherwise the format would be invalid when it's printed. Please refer to the content of Table 5-3 <i>Descriptions of Barcode Data Items</i> and Table 5-4 <i>Factory Default Barcode</i> .
Save editing barcode	【Amend】	P25	BAR.00	NoSet	0	Continue to edit other barcodes.
Return to sale mode	【Sale】	0.000	0.000	0.00	0.00	[[Sale]], [[Sum]] on.

Table 5-1 List of Barcode Types

Barcode formats	Instruction	Valid number digit (suggest)
0	Default	
1	EAN13	12
2	EAN8	7
3	UPC A	11
4	UPC E	6
5	EAN-128	Even or Odd with Checksum
6	Code-128C	Even or Odd with Checksum
7	ITF-25	Even or Odd with Checksum

Note 1 When select default, it will auto select the most reasonable barcode format according to valid number digit

Note 2 When print EAN-128, Code-128C or ITF-25, if length of number is odd number, it will auto add one checksum at the end. The arithmetic is same as EAN/UPC checksum

Table 5-2 Check Digit of Barcode

Check ways	0	All checks
	1	End Check
	2	Middle Check
	3	Not check

Note 1 Check digit of barcode for barcode formats is just an advice for the scale. The scale would process the check based on the selected barcode format. For example, EAN13 is verified by End Check no matter which kind of check is selected.

Table 5-3 Descriptions of Barcode Data Items

Items	Restrictions	Instructions	
Data Source	A~Z	A	Not print
		B	Spec Flag
		C	Constant Num 1
		D	Constant Num 2
		E	PLU Number
		F	PLU Item-Code
		G	PLU Index
		H	PLU Flag
		I	PLU real U.Price
		J	PLU count/weight
		K	PLU T.Price
		L	Sale T.Price
		M	Sale T.Count
		N	Sale T.Weight
		L	Add-up Times
		P	Sales man number
		Q	Sale date: year
R	Sale date: month		
S	Sale date: date		
Display Length	0~9	Print length 0~9	
Data Shift	0~9	Move to right 0~9 digits	
Overflow management	0~3	0: not print	
		1: truncation print	
		2: fill in with character 0	
		3: fill in with character 9	

Table 5-4 Factory Default Barcode

Number	Name	Descriptions	Use	Instructions
1	B-Item 1	B201E500K500A000A000A000	Item barcode	2 digits Spec Flag, 5 digits PLU Number, 5 digits PLU T.Price.
2	B-Item 2	B201F500K500A000A000A000	Item barcode	2 digits Spec Flag, 5 digits PLU Item-Code, 5 digits PLU T.Price.
3	B-Item 3	F700K500A000A000A000A000	Item barcode	7 digits PLU Item-Code, 5 digits PLU T.Price.

4	B-Item 4	B201E400K600A000A000A000	Item barcode	2 digits Spec Flag, 4 digits PLU Number, 6 digits PLU T.Price.
5	B-Item 5	B201F400K600A000A000A000	Item barcode	2 digits Spec Flag, 4 digits PLU Item-Code, 6 digits PLU T.Price.
6	B-Item 6	F600K600A000A000A000A000	Item barcode	6 digits PLU Item-Code, 6 digits PLU T.Price.
7	B-Sum 1	B701L500A000A000A000A000	Total barcode	7 digits Spec Flag, 5 digits Sale T.Price.
8	B-Sum 2	B601L600A000A000A000A000	Total barcode	6 digits Spec Flag, 6 digits Sale T.Price.
9	B-Sum 3	B501L700A000A000A000A000	Total barcode	5 digits Spec Flag, 7 digits Sale T.Price.

5.4.6 Print Formats Programme

Number	Use	Instructions
1~9	Factory default	Already edited when the scale is released from factory
10~39	User's print format	Print format can be edited by users

Different print formats are needed in various applications. Some print types are already edited when the scale is released from factory. Users could choose some formats from them or edit the format for themselves. **It's very hard to edit print format on the scale. Suggest users do not edit print format on the scale.**

This chapter would not offer any examples about print formats edit. Users should use the software on PC to edit print formats or write down demands and send them to us. We will edit the print format you need.

Table 5-5 Factory Default Print Formats

No.	Format	Gap Paper	Plain Paper
1	Item Label	58mm*40mm	58mm
2	Item Label	40mm*30mm	40mm
3	Item Label	58mm*30mm	58mm
4	Total Label	58mm*40mm	58mm
5	Total Label	40mm*30mm	40mm
6	Total Label	58mm*30mm	58mm
7	Receipt		58mm
8	Receipt		40mm
9	Receipt		48mm

Note 1 If users use gap paper in size of 58mm*30mm, set the value of Spec000 to 1, Spec001 to 4.

Note 2 If users use gap paper in size of 40mm*30mm, set the value of Spec000 to 2, Spec005 to 5.

Note 3 If users use gap paper in size of 58mm*30mm, set the value of Spec000 to 3, Spec005 to 6.

Note 4 If users use plain paper in width of 58mm, set the value of Spec000 and Spec005 to 7

Note 5 If users use plain paper in width of 40mm, set the value of Spec000 and Spec005 to 8.

Note 6 If users use plain paper in width of 48mm, set the value of Spec000 and Spec005 to 9.

Table 5-6 Factory Default Print Formats for cash register scale

No.	Format	Gap Paper	Plain Paper
1	Receipt	48mm	Print PLU number

2	Receipt	48mm	Print number
3	Receipt	48mm	New Line mode with Name
4	Receipt	48mm	Large Font Mode
8	List	48mm	Cookroom Use List
9	List	48mm	Cookroom Use List, Large Font Mode

Note 1 User can use format 8 or 9, when remote printer is used as a cookroom printer.

If user really need to edit print format on the scale, please refer to 5.2.3 *List of Programme Interface* of P26 print format, following table are example to user refer:

Table 5-7 Print format: Print-item instruction

Print Item	Name	Sort	Length	Number Range	Instruction
Item No.	Number	Number	1	0~99	Unique number with order
Sign 1	Flag1	Code	1	Refer to later table	
Sign 2	Flag2	Code	1		
Sign 3	Flag3	Code	1		
Print State	Print	Code	1	0~255	0: Not Print
					1: Print
					2: By-weight PLU print
					3: By-count PLU print
					4: Temporary PLU print
					5: Tared PLU print
					6: Free PLU print
					7: Print with sale date
					8: Print with packing date
					9: Print with shelf date
					10: Not 1pcs PLU print
					11: Item service charge print
					12: Service charge print
					13: Taxed PLU print
	Other: not defined				
Angle	Angle	Code	1	0~3	Clockwise rotation: Angle*90
Snap to grid	Grid	Code	1	0~9	1~9: 9 position, 0: default
Font	CFont	Code	1	3~5	Version before V2.03
				0~9	Version after V2.03 and V2.03
X Position	S-X	Coordinate	2	0 ~ 65535	Start coordinate for print area
Y Positon	S-Y		2	0 ~ 65535	
Width	L-X	Coordinate	2	0 ~ 65535	Height and width for print area
Height	L-Y		2	0 ~ 65535	

Table 5-8 Print format: Print-item code

Flag1		Flag2		Flag3		
Code	Content	Code	Content	Code	Content	
0	Barcode	0	Readable			Flag3 blank means no effect. Followed are the same
		1	Not Readable			
1	Item Info	0	X	0	Name	'X' in Flag2 means print all cargo in turn. If Flag2=3, it means print the information for the third accumulate cargo's
		1	1	1	Amount	
		2	2	2	Tare	
		3	3	3	First Unit Price	
		4	4	4	Payable Unit Price	

		5	5	5	Price	
		6	6	6	PLU Number	
		7	7	7	Class Number	
		8	8	8	Dept. Number	
		9	9	9	Index	
		10	10	10	Item-Code	
		11	11	11	Sale Date	
		12	12	12	Sale Time	
		13	13	13	Package Date	
		14	14	14	Package Time	
		15	15	15	Shelf Date	
		16	Text 1	
		18	18	17	Text 2	
		19	19	18	Text 3	
		20	20	19	Text 4	
		21	21	20	Text 5	
		22	22	21	Text 6	
		23	23	22	Text 7	
		24	24	23	Gross	
		25	25	24	Measure Unit	
		26	26	25	Price Unit	
		27	27	26	Price without Tax	
		28	28	27	Tax	
		29	29	28	Item Service Fee	
		30	30	29	Tax Rate	
		31	31	30	PLU No and Name	
2	Sale Info	0	Store Name			
		1	Device Name			
		2	Device Number			
		3	Print Date			
		4	Print Time			
		5	Add-up Times			
		6	Total Count			
		7	Total Weight			
		8	Total Price			
		9	Payment			
		10	Change			
		11	Rounding Money			
		12	Unit of Weight			
		13	Unit of Weight Price			
		14	Unit of Count			
		15	Unit of Count Price			
		16	Unit of Money			
		17	Device Postil 1			
		18	Device Postil 2			
		19	Device Postil 3			
		20	Device Postil 4			
		21	Device Postil 5			

		22	Device Postil 6			
		23	Device Postil 7			
		24	Device Postil 8			
		25	FID	0~8	Least Digital	
		26	SID	0~8	Least Digital	
		27	Net Price			
		28	Gross Price			
		29	Money of Discount and Rounding			
		30	Salesman No.			
		31	Salesman Name			
		32	Total Price without Tax			
		33	Total Tax			
		34	Waiter Number			
		35	Waiter Name			
		36	Text of Item Service Fee			
		37	Text of Service Fee			
		38	Industry Mark			
		39	Reserved 4			
		40	Reserved 5			
		41	Reserved 6			
		42	Reserved 7			
		43	Reserved 8			
		44	Service Fee			
		45	Tax of Service Fee			
		46	Service Fee without Tax			
		47	Buffer Number			
3	Const Text	0~15	0~15			Flag2 is text series number
4	Outline Border	1~24	1~24			Flag2 is outline boarder thickness
5	Partition	0	Area Flag	0~32	0mm~32mm	
		1	Page Print			
		2	Line Print			

5.4.7 Salesman Programme

Example 5-11 Salesman Programme

Operations	Keys	Display				Remarks
		Tare	Weight/Count	Change/U.Price	Single/Total	
〔Sale Idle〕		0.000	0.000	0.00	0.00	〔Sale〕, 〔Sum〕 on.
Enter programme	〔Prog〕	P1	TMSset			〔Prog〕 on.
			Step No.	Step Info	Object	
Enter DTSet	〔2〕	P21	DTSet	Dept		
Enter salesman programme	〔7〕	P27	SAL.00	NoSet	0	
Enter salesman 10	〔1〕〔0〕	P27	SAL.00	NoSet	10	
Next	〔→〕	P27	SAL.01	Name	OK-Edit	
Edit salesman name						Process is omitted.

Next	【→】	P27	SAL.02	Pass	0	
Edit salesman password						
Save editing salesman	【Amend】	P27	SAL.00	NoSet	0	Continue to edit other salesmen.
Return to sale mode	【Sale】	0.000	0.000	0.00	0.00	〔Sale〕 , 〔Sum〕 on.

Note 1 Number 1~99 is the content for users to edit.

5.5 Assistant Data Programme

5.5.1 Steps Select of PLU Programme

Example 5-12 Steps Select of PLU Programme

Operations	Keys	Display				Remarks
		Tare	Weight/ Count	Change/ U.Price	Single/ Total	
〔Sale Idle〕		0.000	0.000	0.00	0.00	〔Sale〕 , 〔Sum〕 on.
Enter programme	【Prog】	P1	TMSet			〔Prog〕 on.
Enter DTAss	【3】	P31	DTSset	Sk-PLU		
Enter step selection of PLU prog	【1】	P31	PLU.00	NoSet	Prog 0	
			PLU Step	Step Info	Prog or Skip	
Select step: ICode	【→】	P31	PLU.01	ICode	Prog 0	
Select step: Index Barcode	【→】	P31	PLU.02	Index	Skip 1	Default index number is not activated.
Enable step: Index Barcode	【↓】	P31	PLU.02	Index	Prog 0	Amend to activation.
Select step: Unit	【→】	P31	PLU.03	Unit	Prog 0	
Select step: U.Price	【→】	P31	PLU.04	Price	Prog 0	
Select step: Cost	【→】	P31	PLU.05	Cost	Prog 0	Default cost is activated.
Disable step: Cost	【↓】	P31	PLU.05	Cost	Skip 1	Amend to not activated.
Save steps selection	【Amend】	P31	DTSset	Sk-PLU	0	
Return to sale mode	【Sale】	0.000	0.000	0.00	0.00	〔Sale〕 , 〔Sum〕 on.

Note 1 The steps above activate steps **Index Barcode** and shield steps **Cost**. And then there is a step to input index in the programme of P23, but no step to input cost. Select Prog or Skip by pressing 【0】\【1】 or 【↑】\【↓】. If Prog is selected, the step is in the programme. If Skip is selected, the step is skipped and not in programme.

Note 2 Amended content would be in effect only in PLU programme and not effective in fast-prog.

5.5.2 Steps Select of PLU Fast Programme

Example 5-13 Steps Select of PLU Fast Programme

Operations	Keys	Display				Remarks
		Tare	Weight/ Count	Change/ U.Price	Single/ Total	
〔Sale Idle〕		0.000	0.000	0.00	0.00	〔Sale〕 , 〔Sum〕 on.
Enter programme	【Prog】	P1	TMSet			〔Prog〕 on.
Enter DTAss	【3】	P31	DTSset	Sk-PLU		
Enter step selection of	【2】	P32	PLU.00	NoSet	Prog 0	

PLU fast prog			PLU Step	Step Info	Prog or Skip	
Select step: ICode	【→】	P32	PLU.01	ICode	Prog 0	
Select step: Index	【→】	P32	PLU.02	Index	Skip 1	Default index number is not activated.
Enable step: Index	【↓】	P32	PLU.02	Index	Prog 0	Amend to activation.
Select step: Unit	【→】	P32	PLU.03	Unit	Prog 0	
Select step: U.Price	【→】	P32	PLU.04	Price	Prog 0	
Select step: Cost	【→】	P32	PLU.05	Cost	Prog 0	Default cost is activated.
Disable step: Cost	【↓】	P32	PLU.05	Cost	Skip 1	Amend to not activated.
Save steps selection	【Amend】	P32	DTSset	Sk-PLU	0	
Return to sale mode	【Sale】	0.000	0.000	0.00	0.00	〔Sale〕 , 〔Sum〕 on.

Note 1 The processes are the same as Example 5-12 only if amended contents only work in PLU fast-prog instead of PLU programme.

5.5.3 Delete Sale Data

When entering the interfaces of delete, users would be requested to receive validate code. Validate code is 9958. Confirm and enter delete process.

Example 5-14 Delete PLU20 ~ 30

Operations	Keys	Display				Remarks
		Tare	Weight/Count	Change/U.Price	Single/Total	
〔Sale Idle〕		0.000	0.000	0.00	0.00	〔Sale〕 , 〔Sum〕 on.
Enter programme	【Prog】	P1	TMSset			〔Prog〕 on.
Enter DTAss	【3】	P31	DTSset	Sk-PLU		
Enter interface of delete	【3】		Input	Code	0	Request input validate code .
Input validate code	【9】【9】【5】 【8】		Input	Code	9958	
Confirm validate code	【Confirm】	P331	DTSset	Delete	Dept	【1】 : Dept., 【2】 : Class, 【3】 : PLU, 【4】 : Unit, 【5】 : Barcode, 【6】 : Print Format 【7】 : Salesman.
Select to delete PLU	【3】		Input	2 - 1	0	
Input start number	【2】【0】 【Confirm】		Input	2 - 2	0	
Input end number	【3】【0】 【Confirm】	P333	DTSset	Delete	PLU	
Return to sale mode	【Sale】	0.000	0.000	0.00	0.00	〔Sale〕 , 〔Sum〕 on.

Note 1 Once confirming to delete object, users shall be requested to input 2 numbers. And system would delete data objects in the range between the two numbers. If the 2nd number is 0, the object appointed by 1st number is deleted. If 2nd number is less than 1st number, no object is deleted.

5.6 Communication and Data Update

5.6.1 Operations of files in USB flash Disk.

Data edited on PC could transfer by USB flash disk.

The software would create a file in the directory of JHSCALE when exporting a file to USB flash disk.

If users export auto-update file, the form of file is A_XXX.TMS. If the scale has set USB flash disk auto-update (factory default setting), after switch on, the scale would update the data when system detects the file in USB flash disk

In P41, press **【×】** to select auto-update file A_XXX.TMS, or input number to select numbered files from A_000.TMS to A_999.TMS (The number is file serial number). Press **【Confirm】** to load file data and update the information in the scale. Or press **【Amend】** to save scale information to appointed file.

Example 5-13 Load Files in USB Flash Disk

Operations	Keys	Display				Remarks
		Tare	Weight/ Count	Change/ U.Price	Single/ Total	
『Sale Idle』		0.000	0.000	0.00	0.00	[[Sale]], [[Sum]] on.
Enter programme	【Prog】	P1	TMSet			[[Prog]] on.
Enter Commu	【4】	P41	Commu	U-Disk		Make sure USB flash disk exists.
Enter operation of USB flash disk	【1】	P41	Commu	U-Disk	000	
Appoint auto-update file	【×】	P41	Commu	U-Disk	XXX	Input number here to load numbered file. Please make sure selected files are in the directory JHSCALE.
Load files	【Confirm】	0	0	0	Dw-Data	When operation finishes normally, the state change into finish.
		Number of Error Data	Number of Right Data	Number of Bytes	Working State	
Several seconds		0	Finish	
Exit	【Confirm】	P41	Commu	U-Disk		Press any key to quit.
Return to sale mode	【Sale】	0.000	0.000	0.00	0.00	[[Sale]], [[Sum]] on.

Note 1 If file is loading ends normally, system would change the state into Finish. Normally, the amount of error commands should be 0.

Note 2 If system encounters with invalid files or other serious mistakes, change the state into Error.

Note 3 In the state of Finish or Error, press any key to exit. If users want to exit midway, press **【Cancel】** .

Example 5-14 Save working data to Files in USB Flash Disk

Operations	Keys	Display				Remarks
		Tare	Weight/ Count	Change/ U.Price	Single/ Total	
『Sale Idle』		0.000	0.000	0.00	0.00	[[Sale]], [[Sum]] on.
Enter programme	【Prog】	P1	TMSet			[[Prog]] on.
Enter Commu	【4】	P41	Commu	U-Disk		Make sure USB flash disk

						exists.
Enter operation of USB flash disk	【1】	P41	Commu	U-Disk	000	
Appoint numbered file	【1】【2】	P41	Commu	U-Disk	012	Press 【×】 to select auto-update file.
Save file	【Amend】	0	0	0	Up-Data	When operation finishes normally, the state change into finish.
		Data Sort	Data Number	Number of Saved Data	Working State	
Several seconds		Finish	
Exit	【Confirm】					
Return to sale mode	【Sale】	0.000	0.000	0.00	0.00	[[Sale]], [[Sum]] on.

Note 1 Exporting data to files in USB flash disk may take a lot of time. Please wait.

Note 2 Press any key to exit when saving is ended. If users want to exit midway, press **【Cancel】**.

Example 5-15 Save sale list to Files in USB Flash Disk

Operations	Keys	Display				Remarks
		Tare	Weight/Count	Change/U.Price	Single/Total	
[[Sale Idle]]		0.000	0.000	0.00	0.00	[[Sale]], [[Sum]] on.
Enter programme	【Prog】	P1	TMSet			[[Prog]] on.
Enter Commu	【4】	P41	Commu	U-Disk		Make sure USB flash disk exists.
Enter operation of USB flash disk	【1】	P41	Commu	U-Disk	000	
Appoint numbered file	【1】【2】	P41	Commu	U-Disk	012	Press 【×】 to select auto-update file.
Save file	【PLU】	0	0	0	Up-Data	【PLU】 save the un-uploaded sale list 【F-Prog】+【PLU】 save all un-deleted sale list(PC software's repeat upload)
		Data Sort	Data Number	Number of Saved Data	Working State	
Several seconds		Finish	
Exit	【Confirm】					
Return to sale mode	【Sale】	0.000	0.000	0.00	0.00	[[Sale]], [[Sum]] on.

Note 1 Exporting data to files in USB flash disk may take a lot of time. Please wait.

Note 2 Press any key to exit when saving is ended. If users want to exit midway, press **【Cancel】**.

5.6.2 Ethernet Monitor Interface

Example 5-16 Enter Ethernet Monitor Interface

Operations	Keys	Display				Remarks
		Tare	Weight/Count	Change/U.Price	Single/Total	
[[Sale Idle]]		0.000	0.000	0.00	0.00	[[Sale]], [[Sum]] on.

Enter programme	【Prog】	P1	TMSet			[[Prog]] on.
Enter Commu	【4】	P41	Commu	U-Disk		Make sure USB flash disk exists.
Enter Ethernet monitor interface	【2】	0	0	0	Dw-Data	Ethernet download information and Stat. information
		Number of Error Data	Number of Right Data	Number of Bytes	Working State	
Transfer upload and download	【×】	0	0	0	Up-Data	Ethernet upload information and Stat. information
		Data area	Data number	Saved data	Working State	
Exit	【Cancel】	P42	Commu	Ethernet		Press any key to quit. If want to exit in the midway, press 【Cancel】
Return to sale mode	【Sale】	0.000	0.000	0.00	0.00	[[Sale]], [[Sum]] on.

Note 1 This monitor interface is usually used when the scale is set to not update in real-time on Internet.

5.6.3 RS232 Communications

The interface is similar to ethernet monitor interface. If want to process RS232 communication, must first enter this interface

5.7 Hardware Assistant

5.7.1 Validate Code

On the purpose of preventing any misoperation in important operation interfaces, users are requested to input validate code when entering these operation interfaces. The interface is shown below:

	Input	Code	0
--	-------	------	---

Validate code of this scale is 9958. When the scale requests to input validate code, users should first make sure whether this operation interface is the one you intend to enter and understand the meaning of this operation. Then input validate code and do operations.

5.7.2 Password

Password is the code to obtain the right to operate the scale. And there are 5 passwords in all.

Amend steps	Types	Password type	Permission	Original password
P511	Admin	Admin password	Hardware Assistant (P51) Sale interface Prog interface Account interface	200806 Please keep it safe if users amend it.
P512	Sale	Sale password	Sale interface	0
P513	Prog	Program password	Prog interface	0
P514	Account	Account password	Account interface	0

Note 1 That Password is 0 means no passwords needed. Users could set the password to be 0 when canceling the password.

Note 2 Admin password is in a higher level than the other 4 passwords. Users do not need to input any

password to enter all interface if admin password is 0 , no matter whether the other passwords are 0.

Note 3 If users want to protect Prog interface or Account interface, first change the admin password other than factory default, then set passwords of corresponding interfaces.

Note 4 Spec247's password hold function can let the device remember the entered password, then, user do not need to input the same password repeatedly

Example 5-17 Process of Amending Passwords

Operations	Keys	Display				Remarks
		Tare	Weight/ Count	Change/ U.Price	Single/ Total	
〔Sale Idle〕		0.000	0.000	0.00	0.00	〔Sale〕 , 〔Sum〕 on.
Enter programme	【Prog】	P1	TMSset			〔Prog〕 on.
Enter hardware Assistant	【5】		Input	Pass	0	
Input admin password		Input	Pass	-----	Display dashes is the as many as input numbers.
Confirm password	【Confirm】	P51	HwAss	Set-PW		
Amend password	【1】	P511	HwAss	Set-PW	Admin	
Amend prog password	【3】		Input	Pass-1		【1】 : admin password 【2】 : sale password 【3】 : program password 【4】 : account password 【5】 : 【 open drawer 】 password
Input password 【Confirm】		Input	Pass-2	-----	
Repeat password 【Confirm】	P513	HwAss	Set-PW	Prog	
Return to sale mode	【Sale】	0.000	0.000	0.00	0.00	〔Sale〕 , 〔Sum〕 on.

Note 1 Input password must match for two times so that password setting can be done.

5.7.3 Recover Factory Default Setting

Example 5-18 Process of Amending Passwords

Operations	Keys	Display				Remarks
		Tare	Weight/ Count	Change/ U.Price	Single/ Total	
〔Sale Idle〕		0.000	0.000	0.00	0.00	〔Sale〕 , 〔Sum〕 on.
Enter programme	【Prog】	P1	TMSset			〔Prog〕 on.
Enter hardware Assistant	【5】		Input	Pass	0	
Input admin password		Input	Pass	-----	Display dashes is the as many as input numbers.
Confirm password		P51	HwAss	Set-PW		
Recovery factory default	【2】	P521	HwAss	TMS-DF	Fac-Set	
Select the type to amend	【4】		Input	Code	0	Here are 4 recovery types: 【1】 Scale parameter(P1x) 【2】 default working data 【3】 all working data(P2x) 【4】 all parameters and data
Input validate code	【9】【9】【5】【8】		Input	Code	9958	

Confirm validate code	【Confirm】	P521	HwAss	TMS-DF	Fac-All	
Return to sale mode	【Sale】	0.000	0.000	0.00	0.00	[[Sale]], [[Sum]] on.

Note 1 Please pay attention to this. Execute recovery 1 or 4, and then passwords would change to factory default.

Note 2 If user amend the Spec irrelevantly, it will make scale do not work regularly, suggest user to executeP511

Note 3 P524 will let the scale recover to factory default state(all user's data will be deleted)

6 Account Operations

6.1 List of Account Interfaces

Entering to Account interface, the scale would enter a calculate process, which first calculate sale records. Then enter A1 select interface.

Table 6-1 List of Account Interfaces

Menus	Menu Prompt	Instructions	Remarks	State
A1	Total	Total report		
A11	Total Daily	Total daily report		
A12	Total Monly	Total monthly report		
A13	Total Qualy	Total quarterly report		
A14	Total Manly	Total manual report		
A2	Dept	Department report		
A21	Dept Daily	Department daily report		
A22	Dept Monly	Department monthly report		
A23	Dept Qualy	Department quarterly report		
A24	Dept Manly	Department manual report		
A3	Class	Class report		
A31	Class Daily	Class daily report		
A32	Class Monly	Class monthly report		
A33	Class Qualy	Class quarterly report		
A34	Class Manly	Class manual report		
A4	PLU	PLU report		
A41	PLU Daily	PLU daily report		
A42	PLU Monly	PLU monthly report		
A43	PLU Qualy	PLU quarterly report		
A44	PLU Manly	PLU manual report		
A5	Clear	Clear report		
A51	Clear Manly	Clear current manual report information		
A52	Clear All	Clear all reports and records information		
A53	Clear Stock	Clear stock report information		
A54	Clear SID	Clear SID information, reset to 0		
A6	Stock	Stock report		
A61	Stock Print	Stock print		
A62	Stock Audit	Stock update		
A7	List	Sale list report		
A71	List Print	Sale list print		
A8	Sales	Salesman report		
A81	Sales Daily	Salesman daily report		
A82	Sales Monly	Salesman monthly report		
A83	Sales Qualy	Salesman quarterly report		
A84	Sales Manly	Salesman manual report		

6.2 Operations of Printing Report

6.2.1 Print Total Report

Total reports are divided into total daily report, total monthly report, total quarterly report and total manual

report. Each report owns 32 buffer zones (0~31).

Take total daily report as an example: The buffer zone 0 stores total daily report of current day; buffer zone 1 stores total daily report of the last day. The rest may be deduced by analogy. So buffer zone 31 stores total daily report of the day dating back to 31 days ago.

Total monthly report and total quarterly report works in the same way, storing total report of the last x months or quarters (x=0~31).

Total manual report would take operation A51 as time point to divide the storage. The buffer zone delays a position automatically when a report is cleared (That means: Buffer 31 records the information which was stored in buffer 30. By analogy, buffer 1 record the information which was stored in buffer 0 and information stored in buffer 0 is cleared. Then start accumulating in buffer 0.).

When printing total report, system would request to input 2 numbers. And the scale would print total buffer which is added up with the buffers whose numbers are between the 2 input numbers.

Example 6-1 Print Daily Reports of Today and Yesterday

Operations	Keys	Display				Remarks
		Tare	Weight/ Count	Change/ U.Price	Single/ Total	
『Sale Idle』		0.000	0.000	0.00	0.00	[[Sale]], [[Sum]] on.
Enter Account	【Account】	A1	Total			[[Account]] on.
Enter total report	【1】	A11	Total	Daily		【1】: Total report 【2】: Dept. report 【3】: Class report 【4】: PLU report
Enter total daily report	【1】		Input	2 - 1	0	【1】: Daily report 【2】: Monthly report 【3】: Quarterly report 【4】: Manual report
Input start number	【0】【Confirm】		Input	2 - 2	0	Start from today.
Input end number	【1】【Confirm】	End at yesterday.
		A11	Total	Daily	0	Print daily report of today. (Note 4)
		A11	Total	Daily	1	Print daily report of yesterday. (Note 4)
		A11	Total	Daily		End of print.
Return to sale mode	【Sale】	0.000	0.000	0.00	0.00	[[Sale]], [[Sum]] on.

Note 1 If some buffers store no data, these buffers would be skipped off without printing.

Note 2 If end number input is 0, system would only print the buffer appointed by start number.

Note 3 If end number input is not 0 and less than start number, no buffer would be printed.

Note 4 The hints about currently print object may appear on the screen for just a few moment when system is printing.

6.2.2 Print Department Report

The scale could print report of all departments. Operation steps are similar as Print PLU Report.

Only the step to enter is different and 2 input numbers is the department numbers.

6.2.3 Print Class Report

The scale could print reports of all Classes. Operation steps are similar as *Print PLU Report*.

Only the step to enter is different and 2 input numbers is the class numbers.steps

6.2.4 Print PLU Report

The scale could print PLU reports whose number is less than 1000.

When printing PLU reports, system would orderly print those PLU reports whose serial numbers is between the 2 input numbers as well as the 2 input numbers.

Example 6-2 Print PLU Daily Reports with the Numbers from 10 to 20

Operations	Keys	Display				Remarks
		Tare	Weight/ Count	Change/ U.Price	Single/ Total	
『Sale Idle』		0.000	0.000	0.00	0.00	[[Sale]], [[Sum]] on.
Enter Account	【Account】	A1	Total			[[Account]] on.
Enter PLU report.	【4】	A41	PLU	Daily		【1】 : Total report 【2】 : Dept. report 【3】 : Class report 【4】 : PLU report
Enter PLU daily report	【1】		Input	2 – 1	0	【1】 : Daily report 【2】 : Monthly report 【3】 : Quarterly report 【4】 : Manual report
Input start number	【1】【0】 【Confirm】		Input	2 – 2	0	Start from PLU10.
Input end number	【2】【0】 【Confirm】	End to PLU20.
				10	Print	Print daily report of PLU10.
				11	Print	Print daily report of PLU11.
				...	Print	
						End of print.
Return to sale mode	【Sale】	0.000	0.000	0.00	0.00	[[Sale]], [[Sum]] on.

Note 1 If some buffers store no data, these buffers would be skipped off without printing

Note 2 If end number input is 0, system would only print the buffer appointed by start number.

Note 3 If end number input is not 0 and less than start number, no buffer would be printed.

6.3 Clear Report Information

6.3.1 Clear Report Information Manually

The information in manual reports would not be cleared automatically unless users enter A51 (clear current manual report) interface to clear it. After this operation, manual reports of all departments, classes and PLU would be cleared, and total manual report would delay its serial number.

Example 6-3 Clear Information in Manual Report

Operations	Keys	Display				Remarks
		Tare	Weight/ Count	Change/ U.Price	Single/ Total	
『Sale Idle』		0.000	0.000	0.00	0.00	[[Sale]], [[Sum]] on.
Enter Account	【Account】	A1	Total			[[Account]] on.
Enter clear report	【5】	A51	Clear	Manly		
Clear manual report	【1】	----	-----	-----	-----	Wait a few seconds.
		A51	Clear	Manly		
Return to sale mode	【Sale】	0.000	0.000	0.00	0.00	[[Sale]], [[Sum]] on.

6.3.2 Clear All Reports and Records Information

Example 6-4 Clear All Reports and Records Information

Operations	Keys	Display				Remarks
		Tare	Weight/ Count	Change/ U.Price	Single/ Total	
『Sale Idle』		0.000	0.000	0.00	0.00	[[Sale]], [[Sum]] on.
Enter Account	【Account】	A1	Total			[[Account]] on.
Enter clear report	【5】	A51	Clear	Manly		
Clear manual report	【2】		Input	Code	0	Input validate code.
Input validate code	【9】【9】【5】 【8】					
Confirm validate code	【Confirm】	----	-----	-----	-----	
		A52	Clear	All		
Return to sale mode	【Sale】	0.000	0.000	0.00	0.00	[[Sale]], [[Sum]] on.

Note 1 This operation would clear the records of all deals. And it's irreversible. Please operate it carefully.

6.3.3 Clear stock information

Example 6-5 Clear stock information

Operations	Keys	Display				Remarks
		Tare	Weight/ Count	Change/ U.Price	Single/ Total	
『Sale Idle』		0.000	0.000	0.00	0.00	[[Sale]], [[Sum]] on.
Enter Account	【Account】	A1	Total			[[Account]] on.
Enter clear report	【5】	A51	Clear	Manly		
Clear manual report	【3】		Input	Code	0	Input validate code.
Input validate code	【9】【9】【5】【8】					
Confirm validate code	【Confirm】	----	-----	-----	-----	
		A53	Clear	Stock		
Return to sale mode	【Sale】	0.000	0.000	0.00	0.00	[[Sale]], [[Sum]] on.

Note 1 This operation would clear stock report. And it's irreversible. Please operate it carefully.

6.3.4 Reposition SID information

Example 6-6 Clear manual report

Operations	Keys	Display				Remarks
		Tare	Weight/ Count	Change/ U.Price	Single/ Total	
〔Sale Idle〕		0.000	0.000	0.00	0.00	〔Sale〕 , 〔Sum〕 on.
Enter Account	【Account】	A1	Total			〔Account〕 on.
Enter clear report	【5】	A51	Clear	Manly		
Clear manual report	【4】	----	-----	-----	-----	Wait a few seconds.
		A54	Clear	SID		
Return to sale mode	【Sale】	0.000	0.000	0.00	0.00	〔Sale〕 , 〔Sum〕 on.

6.4 Stock Management

6.4.1 Stock Management

A6's stock report and A44's manual PLU report are choiceable(by Spec141) .

Stock report only support first 1000 saved PLU, if the real input PLU number >1000, the partial PLU can notprocess stock management

6.4.2 Stcok Print

When print stock report, it will clue to input 2 digits, scale will in turn print the stock report those PLU reports whose serial numbers is between the 2 input numbers as well as the 2 input numbers.

Example 6-7 Print stock Reports with the Numbers from 10 to 20

Operations	Keys	Display				Remarks
		Tare	Weight/ Count	Change/ U.Price	Single/ Total	
〔Sale Idle〕		0.000	0.000	0.00	0.00	〔Sale〕 , 〔Sum〕 on.
Enter Account	【Account】	A1	Total			〔Account〕 on.
Enter stock management	【6】	A61	Stock	Print		
Enter stock print	【1】		Input	2 – 1	0	
Input start number	【1】 【0】 【Confirm】		Input	2 – 2	0	Start from PLU10.
Input end number	【2】 【0】 【Confirm】	End to PLU20.
				10	Print	Print stock report of PLU10.
				11	Print	Print stock report of PLU11.
				...	Print
						End of print.
Return to sale mode	【Sale】	0.000	0.000	0.00	0.00	〔Sale〕 , 〔Sum〕 on.

Note 1 If some stock reports store no data, these buffers would be skipped off without printing

Note 2 If end number input is 0, system would only print the buffer appointed by start number.

Note 3 If end number input is not 0 and less than start number, no buffer would be printed.

6.4.3 Stock Audit

Example 6-8 Amend PLU10 stock to 100

Operations	Keys	Display				Remarks
		Tare	Weight/ Count	Change/ U.Price	Single/ Total	
『Sale Idle』		0.000	0.000	0.00	0.00	『Sale』 , 『Sum』 on.
Enter Account	【Account】	A1	Total			『Account』 on.
Enter stock management	【6】	A61	Stock	Print		
Enter stock print	【2】		Input	PLU-no	0	
Enter PLU number	【1】【0】	A61	pcs	0	10	Pcs means default count unit. When PLU is for weight, default stockunit is scale's unit kg
	【Confirm】		Stock unit	Present stock	PLUnumber	
Enter stock quantity 100	【1】【0】【0】	A61	pcs	100	10	【Amend】 : amend stock to input number 【Confirm】 : add input number to stock 【F-Prog】 + 【Confirm】 : reduce input number from stock
Amend to the input number	【Amend】	A61	pcs	100	10	
Return to sale mode	【Sale】	0.000	0.000	0.00	0.00	『Sale』 , 『Sum』 on.

Note 1 Use 【F-Prog】 + 【PLU】 can amend the stock unit, make the weight PLU also with count stock.

Generally do not suggest user use this function. Detailed refer to Spec142

6.5 List Print

6.5.1 Sale Log

When user sale in sale interface, sale data will be recorded. This recorded data is source of all account modes' Stat. Date. Device has about 6000~10000 location according to different device's configure. When the log is being over capability, device will delete oldest log according to FIFO rule.

6.5.2 List Print

Example 6-9 Intraday List Print

Operations	Keys	Display				Remarks
		Tare	Weight/ Count	Change/ U.Price	Single/ Total	
『Sale Idle』		0.000	0.000	0.00	0.00	『Sale』 , 『Sum』 on.
Enter Account	【Account】	A1	Total			『Account』 on.
Enter stock management	【7】	A71	List	Print		
Enter stock print	【1】	A71	List	Print	20	Last window display the location number used by intraday
Start print	【Confirm】			1	Print	Print first unit's record

				2	Print	Print second unit's record
				...	Print
						Print finished
Return to sale mode	【Sale】	0.000	0.000	0.00	0.00	[[Sale]], [[Sum]] on

Example 6-10 Appointed Time Period List Print

Operations	Keys	Display				Remarks
		Tare	Weight/ Count	Change/ U.Price	Single/ Total	
『Sale Idle』		0.000	0.000	0.00	0.00	[[Sale]], [[Sum]] on.
Enter Account	【Account】	A1	Total			[[Account]] on.
Enter stock management	【7】	A71	List	Print		
Enter stock print	【1】	A71	List	Print	20	Last window display the location number used by intraday
Enter time period	【×】		Input	Time-1		
		2009	01 01	00 00	00 W-4	
Enter start time	【...】【Confirm】	
			Input	Time-2		
		2009	01 01	23 59	59 W-4	
Enter finish time	【...】【Confirm】	
		A71	List	Print	30	Last window display the location number used by appointed time period
Start print	【Confirm】			1	Print	Print first unit's record
				2	Print	Print second unit's record
				...	Print
						End print
Return to sale mode	【Sale】	0.000	0.000	0.00	0.00	[[Sale]], [[Sum]] on

7 Appendix

7.1 Reference Table For Errors and Its Instructions

Number	Alarm instructions	Methods to handle
E0.00	Alarms for measurements	
E0.01	Weight is not stable when the scale start-up.	Make sure there is no heavy goods on the tray and the tray is stable. If scale still warns, the sensor may go wrong.
E0.02	Exceed the allowed start-up zero range	Make sure there is no heavy goods on the tray and the tray is on the bracket, If scale still warns, the sensor may go wrong.
E1.00	Alarms for operations	
E1.01	Prog data is invalid.	Input valid data again.
E1.02	Input passwords of 2 times to amend password are different	Re-amend password, and make sure 2 times input are the same.
E1.03	The selected print format do not exist	Set print format again
E1.10	Sale at 0 price is forbidden.	The sale whose sell price is 0 is forbidden. Refer to Spec070.
E1.11	Exceed the largest sale price.	Total price or grand total price of sold goods exceeds the largest sale price.
E1.12	Need to return to zero point	Return to weight zero before sale. Refer to Spec069.
E1.13	Exceed accumulative limit	The accumulative times are over buffer accumulat limit
E1.14	There is data in buffer and cannot print in single.	Print the data in buffers first. Then print this sale or switch to other buffers.
E1.15	No cashing mode, cannot executethe cashing operation.	The scale is set to be no cashing mode. Refer to Spec060.
E1.16	Cashing mode with zero change default is forbidden.	Execute cashing operation afer inputing payment amount. Refer to Spec060.
E1.17	Payment is less than sale price.	Charge enough money which is larger than sale price.
E1.18	System cannot execute accumulative operations while locking PLU.	Before accumulative operations, system needs to exit lock PLU (or auto mode) first.
E1.19	System cannot switch buffers into buffer with accumulation while locking PLU.	Operate in current buffern, or exit lock PLU (or auto mode).
E1.20	Not allow no weigh sale for weight goods	Refer to Spec071.
E1.21	Less than smallest sale weight	Weight needs to be larger than smallest sale weight.
E1.22	Larger than largest sale weight	Weight needs to be smaller than largest sale weight.
E1.23	Discounted U.Price has to be less than discount lower limit.	Discounted in allowed range, or amend the allowed range.
E1.24	Discounted U.Price has to be higher than discount upper limit.	
E1.25	Discount is forbidden.	Refer to Spec110
E1.26	Manual weight entry is forbidden	Refer to Spec077
E1.27	Manual weight entry failed for weight is not zero.	Take off goods, or press 【Zero】

Number	Alarm instructions	Methods to handle
E1.28	T-Sale is forbidden	Refer to Spec076
E1.29	Sale of Weight PLU or count PLU is forbidden.	Refer to Spec075
E1.30	Can not enter special sale mode	Selected PLU have conflict with special sale mode, select again
E1.31	Working on forced auto printing after zero-return. PLU Quitting is forbidden.	Finish printing of current PLU.
E1.32	Transfer sale buffer is forbidden under accumulate mode	Press 【 Confirm 】 or 【 Cancell 】 exit the accumulate mode, then go on transfer
E1.33	Transfer sale mode forbidden	Refer to Spec079
E1.34	The scanned barcode can not be parsed	Confirm the scanned PLU have been edited, interior barcode format station right
E1.35	Tare renew function forbidden	Must turn over tare, then go for tare
E1.36	Salesman is not exist	Login with exist personel
E1.37	Salesman's password can not be 0	Login with personel whose password is not 0
E1.38	Service charge is forbidden	Open the function at Spec307
E1.5x	Custom Product Alarm	E1.50~E1.59
E2.01	Forbid F-Prog of PLU	Refer to Spec080.
E2.02	Forbid F-Prog of PLU shortcut keys	Refer to Spec081.
E2.03	Forbid F-Prog of Spec data parameters	Refer to Spec082.
E2.04	Forbid Re-print	Refer to Spec065.
E2.05	Menu quitting via pressing 【 Sale 】 【 Prog 】 【 Account 】 is forbidden.	Quit the menu by press 【 Cancel 】 some times.
E2.06	A44 report forbidden	Refer to Spec141.
E2.07	A6 report forbidden	Refer to Spec141.
E2.09	Illegal reboot	Refer to Spec138.
E6.00	Alarms for peripheral	
E6.10	PTR: Print sensor calibrate wrong	Do calibrate operation with Ethernet Printer
E6.11	PTR: Gap paper is not taken away.	Take away the printed label paper. If the alarm still warns, do calibrate operation with Ethernet Printer
E6.12	PTR: Print mouth is not closed tight.	Install the paper and close mouth.
E6.13	PTR: Printer is working.	Please wait for a few seconds and try again.
E6.14	PTR: Lack of plain paper	Reinstall plain paper or the paper type cannot match.
E6.15	PTR: Lack of gap paper	Reinstall label paper or the paper type cannot match. If the alarm still warns, do calibrate operation with Ethernet Printer
E6.16	PTR: The printer cannot find the gap intervals.	The paper type cannot match and change the type to plain paper or reinstall gap label paper. If the alarm still warns, do calibrate operation with Ethernet Printer
E6.17	PTR: The printer cannot find gap alignment positions.	Label paper is used up or paper type cannot match with set paper type. Please reinstall label paper.
E6.18	PTR: The printer is overheated and it needs to cool down.	Please wait for a few seconds and try again.

Number	Alarm instructions	Methods to handle
E6.19	PTR: There is no response of the printer.	The printer may not be connected or in the state that the printer could not print.
E6.20	PTR: Print sensor calibrate wrong	Printer process do not follow general time order and finish the working, unknown print error
E6.21	PTR: Communication Error	Checkup the Ethernet cable
E7.00	Alarms for hardwares	
E7.01	Some keys are pressed when the scale starts.	Please confirm that no keys are pressed. In this interface, the last window display pressed keys. 8-5 means the key in 8 th column from the left and 5 th row from the top is pressed. In this interface, the second window displays the calibrated times.
E7.10	Print sensor calibrate wrong	Refer to chapter 1.5.5 <i>Abnormity of Gap Paper Print</i> to calibrate again
E7.11	Gap paper is not taken away.	Take away the printed label paper. If there is still alarm this problem, do as the way in chapter 1.5.5 <i>Abnormity of Gap Paper Print</i> to detect.
E7.12	Print mouth is not closed tight.	Install the paper and close mouth.
E7.13	Printer is working.	Please wait for a few seconds and try again.
E7.14	Lack of plain paper	Reinstall plain paper or the paper type cannot match.
E7.15	Lack of gap paper	Reinstall label paper or the paper type cannot match. If there is still alarm this problem, do as the way in chapter 1.5.5 <i>Abnormity of Gap Paper Print</i> to detect.
E7.16	The scale cannot find the gap intervals.	The paper type cannot match and change the type to plain paper or reinstall gap label paper. If there is still alarm this problem, do as the way in chapter 1.5.5 <i>Abnormity of Gap Paper Print</i> to detect.
E7.17	The scale cannot find gap alignment positions.	Label paper is used up or paper type cannot match with set paper type. Please reinstall label paper.
E7.18	The printer is overheated and it needs to cool down.	Please wait for a few seconds and try again.
E7.19	There is no response of the printer.	The printer may not be connected or in the state that the printer could not print.
E7.20	The printer over time	Printer process do not follow general time order and finish the working, unknown print error
E7.23	PDS calibration failed, ignore PDS	Try recalibrate, this failure will not effect general use
E7.30	Alarm for full storage of deals records.	Enter Account interface. Calculate reports and then clear the reports.
E7.40	Time error	Time module error, if scale work for years, then it means to change the battery on main board
E7.50	Harware error	Inside examine and repair code, if restart again andagain, but still exist this question, need return to factory for repair
E7.51		
E7.52		

Number	Alarm instructions	Methods to handle
E7.53		
E7.54	Font file check error	Download font from Software again.
E7.61	No MAC device	Please ask Service for MAC file.
E7.62	Wire-Network module do not exist or working irregular	If no wire-network module in present scheme, please close the network module (Set Spec043=0) .
E7.63	Wireless-Network module do not exist or working irregular	If no wireless-network module in present scheme, please choose wire-network module (Set Spec050=0) .
E7.70	AD work irregular or loadcell irregular	Confirm loadcell install right
E7.81	DC power is too low	If device is working with battery, please charge it first. If user confirm that power is right, please set Spec235=1 to close the power detect module
E7.82	DC power is too high	If device is working with battery, it means battery is not match with the device. If user confirm that power is right, please set Spec235=1 to close the power detect module
E8.00	Alarms for communications	
E8.11	USB flash disk port do not connect with the scale.	Please confirm that the scale used owns U-Disk port. If it owns, and this alarm cannot be cleared after several times' reboot, please use the guarantee.
E8.12	USB flash disk does not exist.	Please confirm that USB-Disk is correctly inserted with two condition: 1. USB-Disk is formatted in FAT12/16/32. NTFS is not supported by device. 2. USB-Disk is bootloaded as FDD. HDD/ZIP are not supported by device.
E8.13	The file in USB flash disk does not exist.	Confirm that appointed files are inside of USB flash disk.

7.2 Definitions of Spec data parameters

Default values are different via different version. Value list blow is cfor reference only.

No.	Content	Range	Remarks	Default	Permission
0	Bill 1: Item Print Format	0~99	0 means not to print, 1~99 are to print in appoint Print formats.	1	0
1	Bill 1: Item Barcode Format	0~99	0 means not to print, 1~99 are to print in appoint barcode formats.	2	0
2	Bill 1: Item Barcode flag	0~9999999		20	0
3	Bill 1: Item Print Times	0~99		1	1
4	Bill 1: Item Print Reverse	0~1	0: No Reverse, 1: Print 180° Reversed	0	1
5	Bill 1: Sum Print Format	0~99	0 means not to print, 1~99 are to print in appoint Print formats.	4	0

No.	Content	Range	Remarks	Default	Permission
6	Bill 1: Sum Barcode Format	0~99	0 means not to print, 1~99 are to print in appoint barcode formats.	7	0
7	Bill 1: Sum Barcode Flag	0~9999999		2099999	0
8	Bill 1: Sum Item Print Times	0~99		1	1
9	Bill 1: Sum Print Reverse	0~1	0: No Reverse, 1: Print 180° Reversed	0	1
10	Bill 2: Item Print Format	0~99	For the second-class Print formats, ordinary users won't use them. Please don't amend them in normal conditions.	0	1
11	Bill 2: Item Barcode Format	0~99		0	1
12	Bill 2: Item Barcode Flag	0~9999999		0	1
13	Bill 2: Item Print Times	0~99		0	1
14	Bill 2: Item Print Reverse	0~1		0	1
15	Bill 2: Sum Print Format	0~99		0	1
16	Bill 2: Sum Barcode Format	0~99		0	1
17	Bill 2 Sum Barcode Flag	0~9999999		0	1
18	Bill 2: Sum Item Print Times	0~99		0	1
19	Bill 2: Sum Print Reverse	0~1		0	1
20	Print Speed Slow Down	0~99	Reduced % of paper speed	0	1
21	Paper Type	0~1	0: Plain Paper, 1: Gap Paper.	1	0
22	Gray Level of Gap Paper	0~15	0 is lightest, 9 is darkest. The print lighter, the damage to print header smaller.	5	0
23	Gray Level of Plain Paper	0~15		5	0
24	Plain Paper: Interval of Each Print	0~99	Unit of setting number is mm.	0	0
25	Plain Paper: Cut-off Position	0~99		35	0
26	Plain Paper: Pre-feed Distance	0~1999	Unit of setting number is dot. Device is reverse feed if number > 1000	16	0
27	Wide of Report Printing	0~99	Unit of setting number is mm.	50	0
28	Font for Report Print	0~2		1	1
29	Heat Protect	0~30	Continuously print appointed time will enter over-heat protect, Please don't amend it.	5	1
30	Feed Sensor Position	0~255	Hardware properties. Please don't amend them without the guidance of professionals.	180	1
31	Narrow Bar Dot Number of Barcode	0~9	0 for Default	0	1
32	Wide Bar Dot Number of Barcode	0~19		0	1
33	Font of Barcode readable character	0~2		0	1
34	Weighing's Anti-shake while Printing	0~19	Hardware property, Please don't amend them without the guidance of professionals.	3	1
35	Auto New Line Mode	0~1	0: Forbidden; 1: Allowed	0	1
36	ITF25 frame mode	0~2	0: No frame; 1: Up and down frame; 2: Around frame	1	1
37	ITF25 frame width	0~31	Frame dots	8	1

No.	Content	Range	Remarks	Default	Permission
38	ITF25 left and right blank width	0~31	Left and right blank dots	20	1
39	Gap Paper: Pre-feed Distance	0~1999	Unit of setting number is dot. Device is reverse feed if number > 1000	0	0
40	Device Number	0~9999999	They are used to distinguish more than one scale. And they can be printed.	0	0
41	RS232 Baud Rate	0~9	0: 300, 1: 600, 2: 1200, 3: 2400, 4: 4800, 5: 9600, 6: 19200, 7: 38400, 8: 57600, 9: 115200.	5	0
42	USB flash disk Auto Update	0~1	0: No Update, 1: Auto Update	1	0
43	Ethernet Mode	0~2	0: Disable; 1: Server Mode; 2: Client Mode	1	0
44	Ethernet Auto Re-connect	0~65535	0: do not try connect again 1~65535: Device will try to connect with PC each appointed second	0	0
45	Ethernet Auto Reboot if Configure Changed	0~1	0: Disable, only reset change Ethernet config. 1: Enable, Ethernet config apply immediately.	1	1
46	Latency Time of USB Linking	0~99	0: Default wait 2s; 1~99: wait 0.1s--9.9s. Suggest clients keep the default set. If some U-disk start slowly, you can try to change the waiting time for longer	0	1
47	USB Power Always ON	0~1	1: Enable	0	1
48	Ethernet Overtime Interval	0~31	Single overtime seconds, over 5 times overtime, Ethernet will disconnect	10	1
49	Password Authorization	0~1	0: Device Operation Only 1: Communication Operation Allowed	0	1
50	Ethernet Type (Need Reset)	0~1	0: Wire-Network; 1: Wireless-Network	0	1
51	Security Mode	0~2	0: No Security; 1: WEP; 2: WPA/WPA2	1	1
52	Security Option	0~1	0: Open System; 1: Shared Key	1	1
53	Domain Type	0~6	0: FCC; 1: IC; 2: ETSI; 3: Spain; 4: France; 5: JapanA; 6: JapanB	2	1
57	RS232 POS Protocol	0~99	Refer to POS Protocol File	0	1
59	Sale Log Auto Save	0~1	1: Sale Log Auto Save to USB-Disk in Account	0	1
60	Cashing Mode	0~3	0: No Cashing Mode, 1: Cashing Mode With Zero Change Default, No Display For Zero Change, 2: Cashing Mode With Zero Change Default, Always Display For Zero Change, 3: Cashing Mode Without Zero Change Default.	1	0
61	Drawer In Sale Operation	0~3	0: Not Open Drawer, 1: Open Drawer 1, 2: Open Drawer 2, 3: Open Drawer 1 and 2.	3	0
62	Press 【Drawer】 in Sale	0~3	For general scale, only drawer 1 is valid, if user have double drawer request, please contact us.	3	0
63	Press 【Drawer】 in Prog	0~3	The added drawer password only limit the 【Drawer】 operation, open the drawer while printing is not limited	3	0
64	Press 【Drawer】 in Account	0~3		3	0

No.	Content	Range	Remarks	Default	Permission
65	Reprint	0~4	0: Reprint Forbidden 1: Print One Piece of Bill 1 2: Print One Piece of Bill 2 3: Print Each Piece of Bill 1 and 2 4: Print Bill 1 and 2 as Sale Operation	3	1
66	Change Display Exit	0~99	0: Push Any Key For Exit, 1~99: Auto Quit Exit Specified Second	0	0
67	Number Tare	0~2	0: Forbidden, 1: Input Value Tare, 2: Floating-point Value Tare.	0	0
68	PLU Tare	0~7	0: Forbidden, No Resume Tare 1: Update If Current Tare Is Zero, No Resume Tare 2. Update if PLU Tare Is Not Zero, No Resume Tare 3. Always Update PLU Tare, No Resume Tare 4: Forbidden, Resume Tare 5: Update If Current Tare Is Zero, Resume Tare 6. Update if PLU Tare Is Not Zero, Resume Tare 7. Always Update PLU Tare, Resume Tare	1	0
69	Zero-Return For Weight Sale	0~2	0: Always need Zero-Return; 1: Zero-Return is need if Weight Changed; 2: No Zero-Return need, Print "*" before weight	1	0
70	Allowed Zero Purchase	0~1	0: Forbid; 1: Allow	0	1
71	No Weigh Sale for Weight PLU	0~2	0: Forbid; 1: Allowed, 1 pc only 2: Allowed, multi pcs allowed	0	0
72	Clear Sale Buffer if Press 【Sale】	0~1	0: Not clear, 1: Clear.	0	0
73	Think 【T-Sale】 As 【U.Price Convert】	0~1	0: Forbid, 1: Allow. Convert the input U.Price unit from T-Sale Unit to Scale unit.	0	0
74	Return of Goods	0~1	0: Forbid, 1: Allow.	0	0
75	PLU forbidden	0~3	0: No forbidden; 1: Weight PLU forbidden; 2: Count PLU forbidden; 3: All PLU forbidden.	0	1
76	T-Sale PLU transfer forbidden	0~3	0: No forbidden; 1: T-Sale Weight PLU forbidden; 2: T-Sale Count PLU forbidden; 3: All T-Sale PLU forbidden;	0	1
77	Manual Weight Entry	0~3	0: Disable, 1-3: Enable	0	0
78	【Auto mode】 Get into Special Sale Mode	0~4	0: Auto mode forbidden 1: Swith to batch print mode 2: Swith to prepack print mode 3: Swith to lock PLU mode 4: Swith to auto print mode	2	0
79	Sale mode select	0~1	0: Forbid, 1: Allow.	1	0
80	PLU Fast-Prog	0~1	0: Forbid, 1: Allow.	1	0
81	ScPLU Fast-Prog	0~1	0: Forbid, 1: Allow.	1	0
82	Spec Fast-Prog	0~1	0: Forbid, 1: Allow.	1	0

No.	Content	Range	Remarks	Default	Permission
83	Unit Price Fast-Prog 【-@】 or 【@Price】	0~3	0: Forbid; 1: long press【-@】 change PLU saved unit price 2: press 【-@】 change PLU default unit price 3: press【-@】change PLU default unit price, long press to enter PLUsaved name edit menu	1	1
85	Stable Waiting: Set Zero (Each 10 for 1 Second)	0~99	Wait several seconds after pressing the key to set zero. If it's stable in time, execute setting zero. If not stable, error beep would sound.	20	0
86	Stable Waiting: Sale (Each 10 for 1 Second)	0~99	Wait several seconds after pressing accumulative or print in sale. If it's stable in time, execute sale. If not stable, error beep would sound.	20	0
87	Dummy PLU	0~1	0: Disable 1: Use dummy PLU, when try to transfer one do not exist PLU, device will use this PLU number or other PLU item empty way to transfer a dummy PLU. For example:: PLU156 do not exist, when transfer, you will get a cargo name PLU-0156 's PLU.	0	1
88	Dummy ScPLU	0~1	0: Disable 1: use dummy ScPLU, if one shout cut key have been edited, then when it is transferred, scale will transfer PLU according to its short cut code. 【SC1】refer to PLU101, 【Shift】【SC1】 refer to PLU201. Etc.	0	1
89	Step-skip of PLU Fast-Prog Equal to PLU Prog	0~1	0: Disable; 1: Enable, P331 and P332 do same effect	1	1
90	Calculating Account Backgroud	0~1	Allow the scale to calculate report data in background. Suggest clients do not edit this item	1	1
91	Log record function	0~1	0: Enable, 1: Disable	0	1
92	Dummy PLU number	0~1	0: use old version, PLU is 10~5999 1: PLU is 1~9999999, temporary PLU number decided by Spec093 and 096	1	1
93	Dummy number for Temporary weight PLU	0~ 9999999	Refer to Spec092	999999 9	1
94	Dummy number for Temporary count PLU	0~ 9999999		999999 8	1
95	Dummy number for Service Charge PLU	0~ 9999999		999999 7	1
96	Dummy number for Discount & Rounding PLU	0~ 9999999		999999 6	1
97	Index barcode from keyboard	0~2		0: Forbidden; 1: Allow use number index 2: Allow use number and character index	1
98	Single count deal: discount sum and rounding sum'smanage	0~5	0: Not Record 1: Independent Record Discount, No Rounding 2: Separate Record Discount, No Rounding	3	1

No.	Content	Range	Remarks	Default	Permission
99	Accumulate deal: discount sum and rounding sum'smanage	0~5	3: Independent Record Discount and Rounding 4: Independent Record Discount, Separate Record Rounding 5: Separate Record Discount and Rounding	3	1
100	Rounding Method for Single Total Price	0~1	0, Common Rounding For Redundancy Digit 1, Common Rounding For Last Digit 2, Common Rounding For Last 2 Digits 3, Banker's Rounding For Redundancy Digit 4, Banker's Rounding For Last Digit 5, Banker's Rounding For Last 2 Digits	0	0
101	Rounding Method for Sum Tota Pricel	0~11	6, Rounding Down For Redundancy Digit 7, Rounding Down For Last Digit 8, Rounding Down For Last 2 Digits 9, Rounding to 0/5 For Last Digit 10, Rounding to 0/5 For Last 2 Digits 11, Rounding to 0/5 For Last 3 Digits	0	0
102	Print with accumulated data	0~1	0: Enable, 1: Disable	0	1
103	Equal Reparation of Tare, Net and Gross	0~3	0: No Reparation; 1: Tare=Gross-Net; 2: Net=Gross-Tare; 3: Gross=Net+Tare	3	1
104	Date Type	0~5	0: YYYY.MM.DD; 1: YY.MM.DD 2: MM/DD/YY; 3: MM-DD-YY 4: DD/MM/YY; 5: DD-MM-YY	0	1
105	Shelf Day Print	0~2	0: Using PLU setting 1: Shelf Printing based-on Spec106 if PLU Do not set Shelf Day 2: Shelf Printing based-on Spec106	0	0
106	Shelf Days	0~999	Shelf life days after intraday. 0 means only for intraday	0	0
107	Number of Sale Buffers	0~99	0: maximum allowed buffer	0	0
108	Number of Maximum Accumulate	0~65535	0: maximum allowed accumulate	0	0
109	Divide Operation of U.Price	0~1	0: Normal Operation; 1: Divide Operation	0	Not open
110	Manual Discount: Forbidden	0~3	0, All Allowed 1, Forbidden U.Price Discount 2, Forbidden T.Price Discount 3, Forbidden All Discount	0	1
111	Manual Discount: Lower Limit (Percent Number)	0~255	0: no lower limit, discount freely; 1~99: Take the percent of U.Price as the lower limit of the discount. 100~255: Don't allow the price after manual discount is lower than original U.Price.	0	0
112	Manual Discount: Upper Limit (Percent Number)	0~255	0: no upper limit, discount freely; 1~100: Don't allow the price after manual discount is higher than original U.Price. 101~255: Take the percent of U.Price as the upper limit of the discount.	0	0

No.	Content	Range	Remarks	Default	Permission
113	Percent Discount Arithmetic	0~1	0: Subtractor, 1: Addition	0	1
114	Auto Percent Discount Rate	0~99	0: Manual input number 1~99: Discount with this number	0	1
115	Auto Discount: Price Lock	0~3	0: No Auto Discount 1: Price Lock if Auto Discount Is Effective 2: Price Lock If Auto Discount Is Setting 3: Price Lock for All PLU Price Discount disable when price is tracking.	1	1
116	Global Tax Sort	0~3	0: No global tax rate 1: Default is exclude Tax with Excluded Rate 2: Default is include Tax with Excluded Rate 3: Defaultx with included Rate	1	0
117	Global tax rate (‰)	0~9999	0.01% tax rate, for 17%, need input 1700	1	0
118	Amend mode in sale	0~2	0: Manual; 1: Record and clear 2: Not record and clear	0	1
119	Scanner checkout	0~2	0: Not checkout, ignore reduncdance information 1: Checkout, ignore reduncdance information 2: Checkout, not ignore reduncdance information	2	1
120	Bar code match calculation	0~3	0: Do nothing 1: Deal with External Barcode (Index mode) 2: Deal with Internal Barcode (Code mode) 3: Deal with all mode	3	1
121	Deal method with code=0	0~2	0: Search user PLU 1: Deal with By-Weight T-Sale PLU 2: Deal with By-Count T-Sale PLU	1	1
122	Internal Barcode 1: Format	0~99	Group 1 interior bar code format, if Spec122=0, device auto use Spec1 and Spec2 as Group 1 interior bar code format	0	0
123	Internal Barcode 1: Flag Number	0~ 9999999		0	0
124	Internal Barcode 2: Format	0~99	Group 2 interior bar code format	0	1
125	Internal Barcode 2: Flag Number	0~ 9999999		0	1
126	Internal Barcode 3: Format	0~99	Group 3 interior bar code format	0	1
127	Internal Barcode 3: Flag Number	0~ 9999999		0	1
128	Internal Barcode 4: Format	0~99	Group 4 interior bar code format	0	1
129	Internal Barcode 4: Flag Number	0~ 9999999		0	1
130	Total Price Masked before Printing	0~1	0: Not enable 1: Enable. Total Price only displays after printing	0	1
131	Auto Printing after Zero-return	0~4	0: Not enable. 1: Auto record after Zero-return. Can press 【Cancel】 to exit, do not record after exit 2: Forced auto record after Zero-return. Force	0	1

No.	Content	Range	Remarks	Default	Permission
			operator to print the trade or take record. 3: Auto Printing after Zero-return. Can press 【Cancel】 to exit, do not record after exit 4: Forced Auto Printing after Zero-return. Force operator to print the trade or take record.		
132	Accu Mode: Transferring PLU by Key Input	0~1	0: Disable 1: Enable	0	1
133	Accu Mode: Transferring PLU by External Barcode	0~1		1	1
134	Accu Mode: Transferring PLU by Internal Barcode	0~1		1	1
135	Salesman mode	0~5	0: No salesman mode, log in with salesman 0. 1: Login V1~V4 with Salesman 1~4, No password 2: Password Enable, V1~V4 by Same Salesman 3: Password Enable, V1~V4 by Different Salesman 4: Password Enable, V1~V4 by Same Salesman, Pass=0 Salesman Cannot login 5: Password Enable, V1~V4 by Different Salesman, Pass=0 Salesman Cannot login	1	0
136	Waiter Mode	0~2	0: Disable 1: Enable, Forbidden dummy personnel 2: Enable, Allowed dummy personnel	0	1
137	Waiter Memory Mode	0~2	0: Always clear; 1: Memory last one 2: Memory in buffer	0	1
138	Right of Default Salesman	0~65535	Please use software	0	1
139	EAN/UCC CRC	0~1	0: Standard, 1: Non-standard	0	1
140	SID auto clear	0~6	0: Disable; 1: Half day clear(12:00 and 0:00) 2: Each day clear; 3: Each Saturday clear 4: Each Monday clear; 5:Each month clear 6: Each quarter clear	2	1
141	Stock report	0~1	0: Disable(A44 Report Enable) 1: Enable(A44 Report Disable)	1	1
142	Stock change unit mode	0~2	0: Only PLU's Unit Allowed 1: Default By-Weight Unit and By-Count Unit Allowed 2: All System Unit Allowed	1	1
143	FID/SID Print Mode	0~9	0: Print as number 1~9: Print in specified length with '#'	6	1
144	Each Item has Identify FID	0~1	0: Forbidden; 1: Enable.	0	1
145	Print extra info in report	0~65535	+1: Print Picture 1; +2: Print global text 0 +4: Print global text 1; +8.....	0	1
150	Scale's Ethernet IP	0~255	When Spec153 is 0, device will connect to network by DHCP. Otherwise use appointed IP to connect the network	192	0
151		0~255		168	0
152		0~255		0	0
153		0~255		0	0

No.	Content	Range	Remarks	Default	Permission
154	PC's Ethernet IP	0~255	When the network under clients state(Spec043=2) , appoint PC's IP.	0	0
155		0~255		0	0
156		0~255		0	0
157		0~255		0	0
158	Scale's Ethernet gateway	0~255	Getway: not use DHCP to connect to network	192	0
159		0~255		168	0
160		0~255		0	0
161		0~255		1	0
162	Scale's Ethernet mask	0~255	Getway: not use DHCP to connect to network	255	0
163		0~255		255	0
164		0~255		255	0
165		0~255		0	0
166	Scale's server port	0~65535	Do not change such setting unless there are expert! Irrelevant change will make the network do not work	33581	1
167	Scale's clients port	0~65535		33582	1
168	Scale's UDP local port	0~65535		33583	1
169	Scale's UDP remote port	0~65535		33584	1
170	Primary DNS	0~255	Primary DNS for dns analysis	8	0
171		0~255		8	0
172		0~255		8	0
173		0~255		8	0
180	Display and Printing of Radix Point	0~1	0: Dot'.'; 1: Comma','	0	2
181	Printing of Kilocharacter	0~3	0: Not printing; 1: Dot'.'; 2: Comma',' 3: Quotation Mark' "	0	2
182	Display of Kilocharacter	0~1	0: Not display; 1: Display based on Spec181	0	2
185	Unit Printing of Weight	0~1	0: No printing; 1: Printing	0	1
186	Unit Printing of Unit Price	0~1	0: No printing; 1: Printing	0	1
187	Unit Printing of Money	0~1	0: No printing; 1: Printing	0	1
188	Unit Price Length	0~6	0: Use System Length; 1~6: Specified Length	0	1
189	Total Price Length	0~7	0: Use System Length; 1~7: Specified Length	0	1
190	5-Windows Scale: PLU Name Display	0~3	0: Auto Fix 1: Font 1 Display 2: Font 0 Display 3: 2-Line Mode	3	1
191	5-Windows Scale: AD-Message display			3	1
192	5-Windows Scale: Display in Idle Mode	0~23	0: Display Time; 1~3: Reserved 4~23: Global String data of Scale (0~19)	3	1
193	5-Windows Scale: Display in accumulated mode		0: Display Accumulation Information 1: Display AD-Message	3	1
194	5-Windows Scale: PLU Info Text Source 1	0~7	0: PLU Name 1~7: Text1~7	0	1
195	5-Windows Scale: PLU Info Text Source 2	0~7		0	1
196	Decimal Point of Count In Barcode Print	0~5	Similar as spec208	3	1
197	Fast Track of Weighing	0~4	0: Default level, 1~4: the bigger, the faster	0	1

No.	Content	Range	Remarks	Default	Permission															
198	Delay of Zero Judgement	0~19	100ms per one	4	1															
199	Delay of Stable Judgement	0~19		0	1															
200	Decimal Point: Tare	0~3	In default state, decimal digits of tare.	3	1															
201	Decimal Point: Weight	0~3	In default state, decimal digits of weight.	3	1															
202	Decimal Point: U.Price	0~5	In default state, decimal digits of U.Price.	2	1															
203	Decimal Point: T.Price	0~5	In default state, decimal digits of T.Price.	2	1															
204	Decimal Point Fix: Tare	0~1	Fix display decimal point according to Spec200	0	1															
205	Decimal Point Fix: Weight	0~1	Fix display decimal point according to Spec201	0	1															
206	Decimal Point Fix: U.Price	0~3	Fix display decimal point according to Spec202 0: No Fix; 1: Fix for Discount; 2: Fix for PLU Call Out; 3: Always Fix.	3	1															
207	Decimal Point Fix: T.Price	0~2	Fix display decimal point according to Spec203. 0: No Fix; 1: Fix based on Spec100; 2: Common rounding before fix based on Spec100	1	1															
208	Decimal Point of Weight In Barcode Print	0~5	For number 1.533, if number here is 2, print 153 when print barcode. If number here is 3, print 1533. The rest may be deduced by analogy. Generally suggest Spec208=Spec201, Spec209=Spec203	3	1															
209	Decimal Point of Money In Barcode Print	0~5		2	1															
210	T-Sale Unit	0~8	0, 1, 2: System Default; 3: kg Unit; 4: g Unit; 5: ton Unit; 6: lb Unit; 7: 500g Unit; 8: 100g Unit; There are some relations among 3 units. Relations are a little different in different editions because the measuring systems are different in different countries.	0	1															
211	System U.Price Unit	0~8		0	1															
212	System Weight Unit	0~8		3	1															
213	Weight Precision	0~3	<table border="1"> <tbody> <tr> <td rowspan="4">TM-30A 30kg</td> <td>0: 10g, 3000</td> </tr> <tr> <td>1: 5g/10g, 6000/3000</td> </tr> <tr> <td>2: 2g/5g, 15000/6000</td> </tr> <tr> <td>3: 1g/2g, 30000/15000</td> </tr> <tr> <td rowspan="3">TM-15A 15kg</td> <td>0: 5g, 3000</td> </tr> <tr> <td>1: 2g/5g, 7500/3000</td> </tr> <tr> <td>2: 1g/2g, 15000/7500</td> </tr> <tr> <td rowspan="3">TM-6A 6kg</td> <td>0: 2g, 3000</td> </tr> <tr> <td>1: 1g/2g, 6000/3000</td> </tr> <tr> <td>2: 0.5g/1g, 12000/6000</td> </tr> <tr> <td colspan="2">3: 0.2g/0.5g, 30000/12000</td> </tr> </tbody> </table> <p>Only precisions of unit kg are listed here. Other units may be a little different. When users use precisions of 2 or 3, weight print would display “*” which means it’s only for industrial use.</p>	TM-30A 30kg	0: 10g, 3000	1: 5g/10g, 6000/3000	2: 2g/5g, 15000/6000	3: 1g/2g, 30000/15000	TM-15A 15kg	0: 5g, 3000	1: 2g/5g, 7500/3000	2: 1g/2g, 15000/7500	TM-6A 6kg	0: 2g, 3000	1: 1g/2g, 6000/3000	2: 0.5g/1g, 12000/6000	3: 0.2g/0.5g, 30000/12000		1	1
TM-30A 30kg	0: 10g, 3000																			
	1: 5g/10g, 6000/3000																			
	2: 2g/5g, 15000/6000																			
	3: 1g/2g, 30000/15000																			
TM-15A 15kg	0: 5g, 3000																			
	1: 2g/5g, 7500/3000																			
	2: 1g/2g, 15000/7500																			
TM-6A 6kg	0: 2g, 3000																			
	1: 1g/2g, 6000/3000																			
	2: 0.5g/1g, 12000/6000																			
3: 0.2g/0.5g, 30000/12000																				
214	Default measure sort	0~1	0: Non-input PLU is by-weight as default 1: Non-input PLU is by-count as default	0	1															
215	Maxium Overflow Degree	0~99	Degree number, there is no limit if number is 0.	9	1															

No.	Content	Range	Remarks	Default	Permission
216	Maxium Underflow Degree	0~99		9	1
217	Minium Sale Degree	0~99		4	1
218	Zero Tracking Degree	0~99999	Unit is: e/10	0	2
219	Tare Range	0~99	Percentage number. No limit if number is 0.	0	2
220	Range of the Initial Zero	0~99		9	2
221	Range of the Single Manual Zero	0~99		2	2
222	Range of the Accumulative Manual Zero	0~99		2	2
223	Zero Flag Range	0~99	Inter-code	4	2
224	Zero Tracking Range	0~99		5	2
225	Stable Flag Range	0~99		6	2
226	Tare can Overrun Capacity 1	0~1	0: Forbidden; 1: Allowed	0	1
227	Tare Update	0~1	0: Forbidden; 1: Allowed	1	1
228	Price Convert between Different Weight Unit	0~2	0: Allowed; 1: Only Default Weight Allowed 2: Forbidden	0	1
229	Weight Switch	0~2	0: Forbidden; 1: Long Press to Switch; 2: Single Press to Switch	1	1
230	AD Anti-shake while printing	0~7	Hardware parameter	2	1
231	Zero forbidden in PLU Mode	0~1	0: Zero is allowed; 1: Zero is forbidden	0	1
232	Floating-point of weight	0~2	0: Always based on low capability 1: Based on current capability, low is priority 2: Based on current capability, high is priority	0	1
233	Zero back is necessary for fast weight unit switch	0~1	0: No need 1: Need	0	1
234	Degrees of Zero back	0~31	Judgement Value of Zero back	0	1
235	Power Detect Module	0~1	0: Enable; 1: Disable	0	1
236	Print in Battery Mode	0~1	0: Print; 1: Not print	0	1
237	Interval of Key Scanner	0~4	Hardware parameter	1	1
238	Anti-shake of Key Scanner	0~4	Hardware parameter	1	1
239	Time for open drawer	0~9999	0~9999ms. Default 100ms	100	1
244	Ignore PBS Sensor	0~1	Use to oblige elimiate error E7.12	0	1
245	Ignore PDS Sensor	0~1	Use to oblige elimiate error E7.11	0	1
246	Ignore PPS Sensor	0~1	Use to oblige elimiate error E7.14	0	1
247	Password hold function	0~3	Password is memoried and no need to input again once it is input. Memory is cleared on restart or parameter amend. 0: Not hold any password 1: Only hold drawer password 2: Hold all password except admin password 3: Hold all password	0	1
249	PLU Text Mode: PLU Text Length ≈ Total Length-150	0~4	0: Default 1: 256 Bytes Mode; 2: 512 Bytes Mode 3: 1024 Bytes Mode; 4: 2048 Bytes Mode	0	1

No.	Content	Range	Remarks	Default	Permission
250	No-Accumulation Mode 【Accu】 is Doing Same Operation as 【Print】	0~1	0: Disable this mode 1: Enable this mode	0	1
251	Discount Menu of Unit Price	0~4	0: Disable discount menu 1: Enable, default mode is based on 【Key】 2: Enable, default mode is PERCENT mode	0	1
252	Discount Menu of Total Price	0~4	3: Enable, default mode is MINUS mode 4: Enable, default mode is FIX mode	0	1
253	Call PLU by “Item-Code” when Press 【PLU】	0~1	0: Based on PLU number 1: Based on PLU Item-Code	0	1
254	Auto 【PLU】 Function	0~3	0: Disable; 1: Enable in idle mode 2: Enable in PLU mode; 3: Enable in all mode	0	1
255	Digit number for auto 【PLU】	0~7	0: Disable 1~7:Auto 【PLU】 after digitals number inputted	0	1
256	Pre-Print Function	0~1	0: Disable; 1: Enable	1	1
260	Need Admin Password In Certain Mode	0~31	0: Normal; +1: Sale; +2: Prog +4: Account; +8: 【Drawer】 ; +16: Unit Price	0	1
261	By-Weight PLU Forbidden in Certain Mode	0~15	0: Normal +1: Batch Print, +2:PrePack, +4:Lock PLU, +8:Auto Print	0	1
262	By-Count PLU Forbidden in Certain Mode			0	1
263	Call PLU automatically in Idle status	0~999999	In idle status, device will call specified PLU automatically	0	1
264	AUTO MODE transaction record as “Auto”, not “Sale”	0~15	+1: Batch Print; +2: Prepack; +4: Lock PLU; +8: Auto Print	0	1
265	Date Print Mode:Month	0~1	0: Digits; 1: Two Characters	0	1
266	Date Display Mode	0~1	0: Default; 1: Using Spec104 and 265	0	1
267	Fast Switch with Weight Unit	0~1	0: Default; 1: Forbidden Non-Standard	0	1
268	Auto Tare Lock	0~1	0: Default; 1: Auto Lock	1	1
269	Print Forbidden	0~1	1: Forbidden Print Model	0	1
270	Weight Display Hidden	0~2	0: Disable; 1: Enable if No PLU; 2: Enable if No Unit Price	0	1
271	Auto Upgrade	0~1	0: Disable; 1: Enable	0	1
272	Filter Mode	0~2	0: Mid-Track; 1: Multi-Average; 2: Suited-Average	0	1
274	Maximum PLU Number	0~999999	0 Means no limit	999999 4	1
275	Uniscribe Script	0~2	0: Disable, 1: RTL in LTR, 2: LTR in RTL	0	1
277	Default Working Mode	0~2	0: Normal; 1: Batch Print; 2: PrePack; 3: Lock PLU; 4: Auto Print.	0	1
278	Hangup Bill Print Format	0~99	0: default; 1~99: specified print format	0	1

No.	Content	Range	Remarks	Default	Permission
279	Hangup and Loadback	0~3	0: Forbidden; 1: Only hangup bill can be load once; 2: Only hangup bill can be load, no times limit; 3: All bill can be load	0	1
280	Salesman authorization	0~1	0: Forbidden; 1: Enable	0	1
282	Payment Operation Forbidden	0~63	0: all enable, 1~63: Please use software	0	1
283	Record of Unconfirmed Data	0~2	0: Disable; 1: Record Priced Operation; 2: Record Priced/Weighted Operation	1	1
287	non-VIP Discount Off	0~99	Percent-Off	0	1
288	VIP Default Discount Off	0~99	0:Same as Spec287, 1~99: Specified Percent Off	0	1
289	Other Transaction Print Format	0~99	0: Default; 1~99: Specified Print Format	0	1
290	Log Text 1	0~14	(Need Special Firmware Version)	0	1
291	Log Text 2	0~14	0: Blank; 1: PLU Name; 2~8: PLU Text1-7;	0	1
292	Log Text 3	0~14	9: Item Code; 10: Index Barcode;	0	1
293	Log Text 4	0~14	11~14: Custom Info 1~4	0	1
294	Keep Custom Info	0~15	0: Auto Clear Custom Info1~4; +1:Keep Custom Info 1; +2:Keep Custom Info 2 +4:Keep Custom Info 3; +8:Keep Custom Info 4	0	1
297	Second Currency Exchange	xxx	Please use software	0	1
298	Second Currency Decimal Dot	0~5	Decimal dot position	0	1
299	Default stable arithmetic	0~3	0: Default; 1: desk scale; 2: platform scale; 3 hanging scale	0	1
300	Item Service Fee	0~2	0: Forbidden 1: Allowed, not collect total percent again 1: Allow, collect total percent again	0	1
301	Item Service Fee: Default Method	0~2	0: Unit price mode; 1: Total price mode; 2: Percent mode	0	1
302	Total Service Fee: Input Method	0~5	0: Manual call, manual input price 1: Manual call, manual input percent 2: Manual call, take auto price 3: Manual call, take auto percent 4: Auto call, take auto price 5: Auto call, take auto percent	0	1
303	Total Service Fee: Auto collect based number	0~9999999	Under price mode, auto account according to price decimal point Under percent mode: unit is ‰	0	1
304	Service Fee: Percent Collection based Number	0~1	0: Based on price before tax 1: Based on price after tax	0	1
305	Tax Sort of Service Fee	0~3	0: No global tax rate 1: Default is exclude Tax with Excluded Rate 2: Default is include Tax with Excluded Rate 3: Defaultx with included Rate	0	1
306	Tax Rate of Service Fee (‰)	0~9999	0.01% tax rate, for 17%, need input 1700	0	1
307	Service Fee Permission	0~1	0: Forbidden, 1: Allowed	1	1
308	Service Fee Re-Input	0~1	0: Forbidden, 1: Allowed	1	1

No.	Content	Range	Remarks	Default	Permission
340	Dot matrix LCD's contrast	0~7	Do not change these settings.	6	1
341	Dot matrix LCD's brightness	0~31		7	1
(PTR, parameters setting for network printer)					
350	PTR: Item print format	0~99	0 means print according to bill 1 format (once using bill 1 format, the barcode format and signals are all according to bill 1)	0	0
351	PTR: Item barcode format	0~99		0	0
352	PTR: Item barcode flag	0~9999999		0	0
353	PTR: Item print Times	0~99		1	1
354	PTR: Item print Reverse	0~1	0: No Reverse, 1: Print 180° Reversed	0	1
355	PTR: Sum Print Format	0~99	0 means print according to bill 1 format (once using bill 1 format, the barcode format and signals are all according to bill 1)	0	0
356	PTR: Sum Barcode Format	0~99		0	0
357	PTR: Sum Barcode Flag	0~9999999		0	0
358	PTR: Sum Item Print Times	0~99		1	1
359	PTR: Sum Item Print Rol	0~1	0: No Reverse, 1: Print 180° Reversed	0	1
360	PTR: network print function	0~3	0: Disable 1: Enable, wait till printing finished 2: Enable, wait till printing started 3: Enable, wait till data sending finished	1	1
361	PTR: printer status clew	0~3	0: No operation 1: Online/offline clew 2: Online/offline clew, alarm when there is no rating printing 3: Online/offline clew, error when there is no rating printing	1	1
362	PTR: rating number for printer	0~20	Alarm or error if less than rating number	0	1
363	PTR: check interval	0~65535	Unit: second, default for 10s	0	1
364	PTR's IP: No.1	0~255		0	0
365		0~255		0	0
366		0~255		0	0
367		0~255		0	0
368	PTR's IP: No.2	0~255		0	0
369		0~255		0	0
370		0~255		0	0
371		0~255		0	0
372	PTR's IP: No.3	0~255		0	0
373		0~255		0	0
374		0~255		0	0
375		0~255		0	0
376	PTR: Server Socket	0~65535		33591	1

No.	Content	Range	Remarks	Default	Permission
377	PTR: Client Socket	0~65535	Do not change such setting unless there are expert! Irrelevant change will make the network printer do not work	33592	1
378	PTR: UDP Local Socket	0~65535		33593	1
379	PTR: UDP Remote Socket	0~65535		33594	1
400	PTR: Print speed decrease	0~99	Reduced % of paper feed speed	0	1
401	PTR: Paper Type	0~1	0: Plain Paper, 1: Gap Paper.	0	0
402	PTR: Gray Level of Gap Paper	0~9	0 is lightest, 9 is darkest. The print color lighter, the damage to print header smaller. Suggest users use lighter grey level.	7	0
403	PTR: Gray Level of Plain Paper	0~9		7	0
404	PTR: Plain Paper: Interval of Each Print	0~99	Set the unit of number is mm. 0 means use default set	0	0
405	PTR: Plain Paper: Cut-off Position	0~99		0	0
406	PTR: Plain Paper: Pre-feed Distance	0~1999	Unit of setting number is dot. Device is reverse feed if number > 1000	0	0
407	PTR: Paper width	0~99		0	0
408	PTR: Default font	0~2		1	1
409	PTR: Printer over-heat protect	0~30	Continuously print appointed time will enter over-heat protect, Please don't amend them without the guidance of professionals.	0	1
410	PTR: Feed Sensor Position	0~255	Hardware properties. Please don't amend them without the guidance of professionals.	180	1
411	PTR: Point numbers for narrow bar in barcode printing	0~9	0 for default set, Please don't amend them without the guidance of professionals.	0	1
412	PTR: Point numbers for wide bar in barcode printing	0~19		0	1
413	PTR: Readable character fonts in barcode printing	0~2		0	1
415	PTR: Auto new line mode	0~1	0: One line mode; 1: Auto new line mode	0	1
416	PTR: ITF25 barcode frame mode	0~2	0: No frame; 1: Up and Down frame; 2: Around frame	1	1
417	PTR: ITF25 barcode frame width	0~31	Frame dots	8	1
418	PTR: ITF25 barcode left and right blank width	0~31	Left and right blank dots	20	1
419	PTR: Gap Paper: Pre-feed Distance	0~1999	Unit of setting number is dot. Device is reverse feed if number > 1000	0	0
420	PTR: Ignore PBS Sensor	0~1	Use to force remove error E6.12	0	1
421	PTR: Ignore PDS Sensor	0~1	Use to force remove error E6.11	0	1
422	PTR: Ignore PPS Sensor	0~1	Use to force remove error E6.14	0	1
450	PDF417: Checksum Level	0~9	0~8: Fix level; 9: System default level	9	1
451	PDF417: Columns Number	0~30	0: Auto sizing, 1~30: Fix number	0	1
452	PDF417: Rows Number	0~90	0~2: Auto sizing, 3~90: Fix number	0	1
453	PDF417: Bar Width	0~6	0: Default 3	0	1
454	PDF417: Bar Height	0~18	0: Default 6	0	1

No.	Content	Range	Remarks	Default	Permission
455	QR: Check Level	0~3		1	1
456	QR: Version	0~31	QR Minimum Version	0	1
457	QR: Bar Size	0~6	0: Default=3	0	1
480 ~499	Custom Version Reserved Spec				

7.3 Definitions of String data parameters

Number	Hint	Text content	Default print format
0	ShopN	Store Name	Print: header center
1	ScaleN	Device Name	Not use
2	MnyPre	Prefix of Money Unit	
3	MnySuf	Suffix of Money Unit	
4	Strg-1	Bill text 1	Print: header center
5	Strg-2	Bill text 2	Print: header left
6	Strg-3	Bill text 3	Print: header center
7	Strg-4	Bill text 4	Print: header left
8	Strg-5	Bill text 5	Print: end center
9	Strg-6	Bill text 6	Print: end left
10	Strg-7	Bill text 7	Print: end center
11	Strg-8	Bill text 8	Print: end left
12	Spst-1	Special text 1	Reserved
13	Spst-2	Special text 2	Reserved
14	Ind-MK	Industry Mark	Industry Mark
15	W-SSID	Wireless SSID	Wireless SSID
16	W-PASS	Wireless Password	Wireless Password
17	Spst-6	Special text 6	Reserved
18	Spst-7	Special text 7	Reserved
19	Spst-8	Special text 8	Reserved

7.4 Definitions of Shortcut Function Key

1	Number:0	2	Number:1	3	Number:2	4	Number:3	5	Number:4	6	Number:5
7	Number:6	8	Number:7	9	Number:8	10	Number:9	11	Number:00	12	Clear
13	Cancel	14	Accu/Confirm	15	Cash/Print	16	PLU	17	F-Prog	18	V1
19	V2	20	V3	21	V4	22	Amend	23	×	24	Feed
25	SetZero	26	SetTare	27	Sale	28	Prog	29	Account	30	Time
31	-%	32	-Num	33	@Price	34	TSale	35	CashBox	38	Manual Weight
39	Paper Type	40	Pre/Re Print	41	Shift	44	Print2	45	CCard	46	MoveDot
47	U.W. Sample	48	Weight Accu	49	Division	50	UnitChange	51	Lock Tare	52	Auto Mode
53	Normal Mode	54	Batch Mode	55	PrePack Mode	56	LockPLU Mode	57	AutoPrint Mode	58	Service Fee
59	←V→	60	Mode	62	On/Off	63	PayOther-0	64	PayOther-1	65	PayOther-2
66	VIP	67	Other Transactions	76	Custom Info 1	77	Custom Info 2	78	Custom Info 3	79	Custom Info 4